



**SARACINESCA A GHIGLIOTTINA MONODIREZIONALE MONOBLOCCO ASTA SALIENTE PN10 CON COMANDO A LEVA**  
**MONOBLOCK KNIFE GATE VALVE MONODIRECTIONAL TYPE RISING STEM PN10 WITH LEVER**

**APPLICAZIONE:**

Fornitura e distribuzione acqua, trattamento acque reflue e sistemi fognari, settori industriali.

**APPLICATION:**

Water supply and distribution, waste water treatment and sewerage.

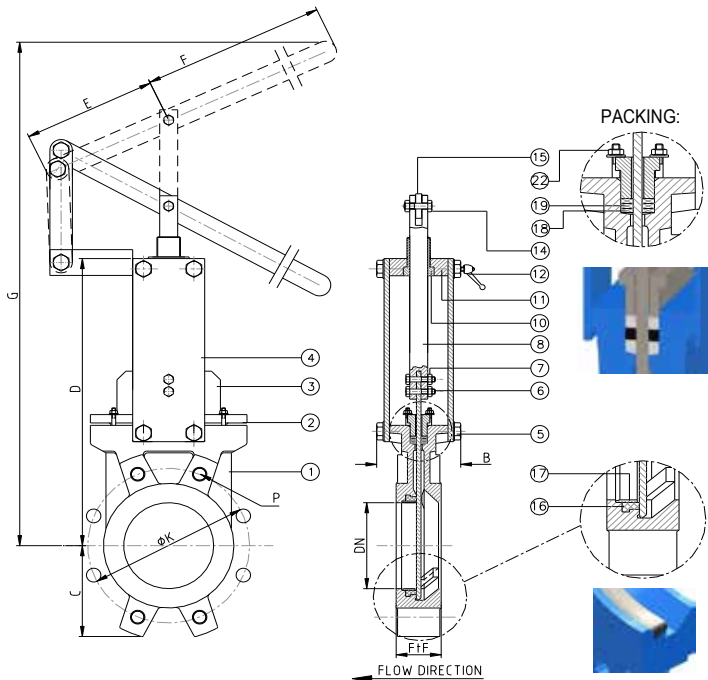

CARATTERISTICHE PRINCIPALI - MAIN FEATURES	
FLANGE:	Foratura secondo EN 1092-2 PN10
COLLAUDI:	EN12266-1 in accordo alla PS della valvola
TEMPERATURA ESERCIZIO:	Max. ≤ +90°C
MINIMA PRESSIONE DI ESERCIZIO:	1 bar (a richiesta 0.1 bar)
FLANGES:	Drilled according to EN 1092-2 PN10
TESTS:	EN 12266-1 according to the valve PS
WORKING TEMPERATURE:	Max. ≤ +90°C
MINIMUM ALLOWABLE WORKING PRESSURE:	1 bar (on request 0.1 bar)

PRESSIONE MASSIMA AMMISSIBILE DI ESERCIZIO (PS): MAXIMUM ALLOWABLE WORKING PRESSURE (PS):		
DN50-250 = 10 bar	DN300-400 = 6bar	DN450-DN600 = 4 bar

RIVESTIMENTO - COATING
Esterno/interno con polvere epossidica di colore blu RAL 5015 e spessore 100µm. External/internal with epoxy resin powder of blue colour RAL 5015 and thickness of 100µm.

DN	K	n-M	FtF	B	C	D	E	F	G	W (kg)
50	125	4-M16	40	90	65	240	150	300	395	8
65	145	4-M16	40	90	68	270	150	300	435	9
80	160	8-M16	50	90	90	295	150	300	458	10
100	180	8-M16	50	90	105	335	150	400	590	12
125	210	8-M16	50	100	120	370	150	400	725	15
150	240	8-M20	60	100	135	418	150	400	892	19
200	295	8-M20	60	120	170	522	232	600	1280	32
250	350	12-M20	70	120	205	625	232	600	1430	44
300	400	12-M20	70	120	240	725	232	600	1580	57

	COMPONENTI - PARTS	MATERIALI - MATERIALS
1	CORPO BODY	EN-GJL 250 EN-GJL 250
2	PREMISTOPPA PACKING GLAND	ALLUMINIO fino a DN300 ALUMINUM up to DN300
3	PARATIA KNIFE	ACCIAIO INOX AISI 304L AISI 304L STAINLESS STEEL
4	SUPPORTO SUPPORT	ACCIAIO STEEL
5 - 6 - 7	BULLONI BOLTS	ACCIAIO INOX A2-70 A2-70 STAINLESS STEEL
8	ASSE STEM	ACCIAIO INOX AISI 304 AISI 304 STAINLESS STEEL
10	MADREVITE STEM NUT	OTTONE BRASS
11	SUPPORTO SUPPORT BRIDGE	ACCIAIO STEEL
12	SISTEMA DI BLOCCAGGIO BLOCK SYSTEM	STANDARD STANDARD
14	BULLONI BOLTS	ACCIAIO INOX A2-70 A2-70 STAINLESS STEEL
15	LEVA LEVER	ACCIAIO STEEL
16	GUARNIZIONE GASKET	GOMMA EPDM EPDM RUBBER
17	ANELLO DI TENUTA SEAT RING	ACCIAIO INOX AISI 316L AISI 316L STAINLESS STEEL
18	BADERNA PACKING	CORDA TEFLONATA SYNTETIC FIBERS + PTFE
19	O-RING BADERNA PACKING O-RING	EPDM EPDM
22	BULLONI BOLTS	ACCIAIO INOX A2-70 A2-70 STAINLESS STEEL

**DETTAGLIO DELLE FLANGE EN1092-2 PN10**  
**EN1092-2 PN10 FLANGE DETAILS**

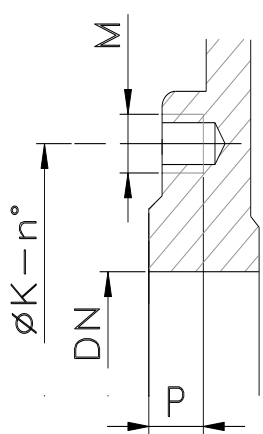
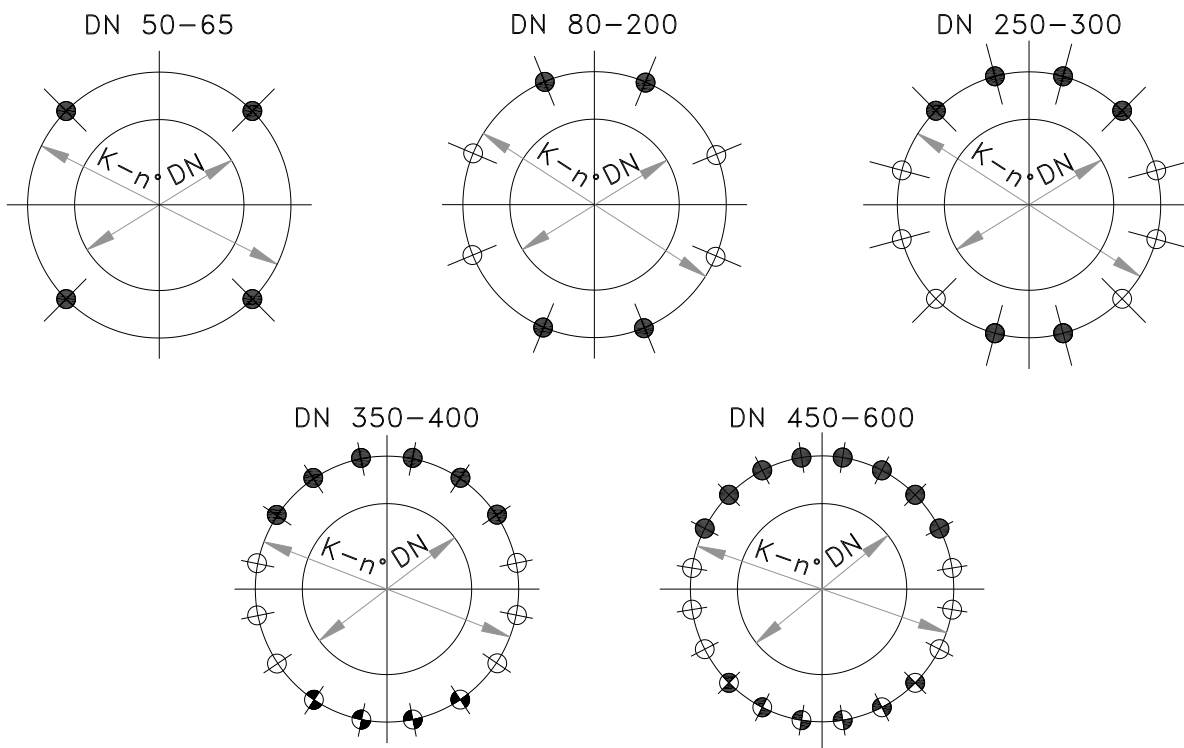

DN	øK	n°	M	P			
50	125	4	M16	10	4	-	-
65	145	4	M16	10	4	-	-
80	160	8	M16	10	4	-	4
100	180	8	M16	10	4	-	4
125	210	8	M16	10	4	-	4
150	240	8	M20	14	4	-	4
200	295	8	M20	14	4	-	4
250	350	12	M20	18	6	-	6
300	400	12	M20	18	6	-	6

- FORO FILETTATO CIECO  
BLIND TAPPED BOLT HOLES
- FORO FILETTATO PASSANTE  
TAPPED TROUGH
- FORI PASSANTI  
TROUGH GOING BORE