

# COMPANY PROFILE

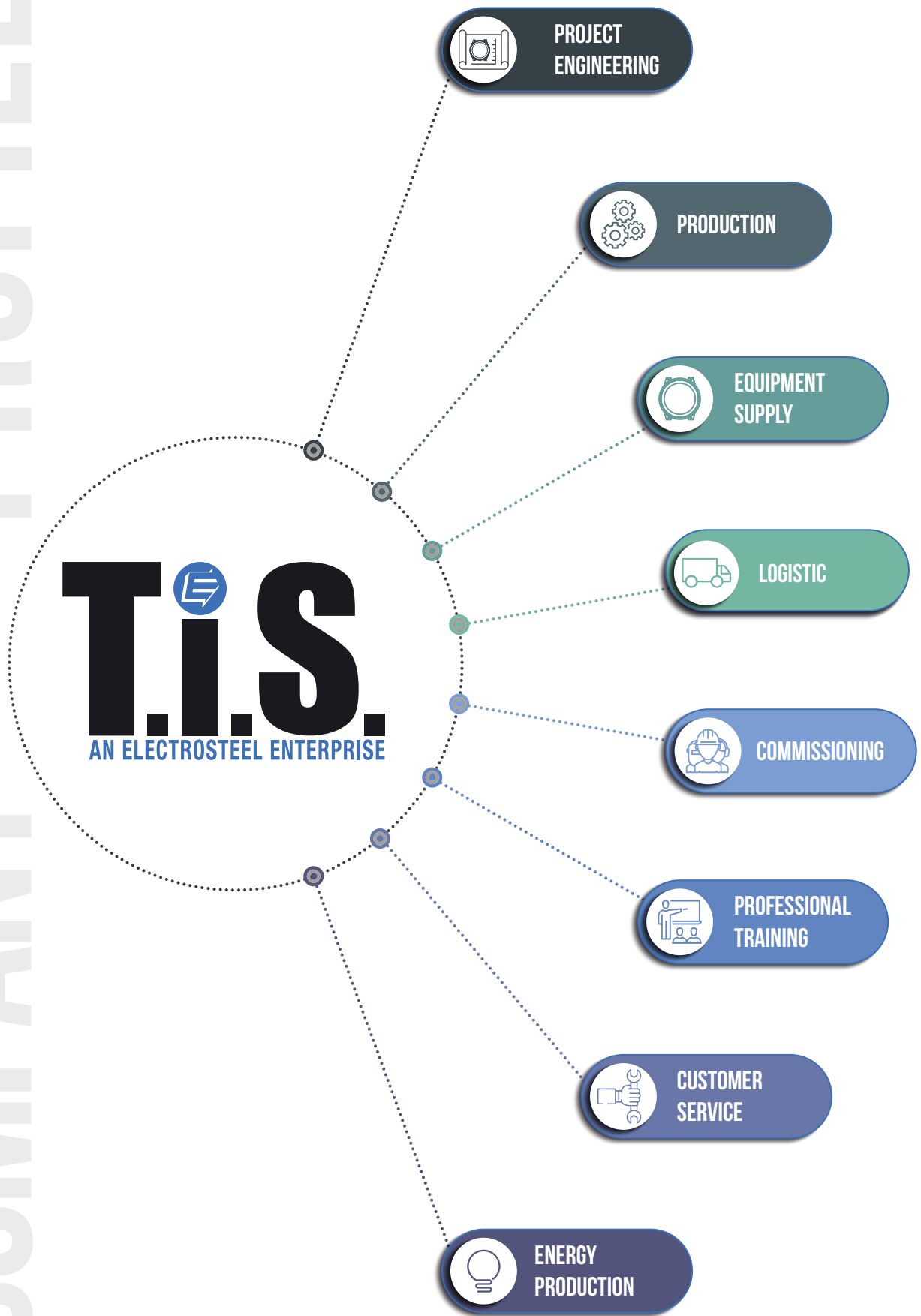

WE PROVIDE SOLUTIONS FOR  
THE EFFICIENCY OF THE WATER NETWORK

WATER IS LIFE,  
SHAPE THE FUTURE.

**ITA** T.I.S. SERVICE S.p.A., azienda leader a livello internazionale, è specializzata nella produzione e nella vendita di apparecchiature per servizi a rete acqua e per centrali idroelettriche. Uno dei prodotti di punta sono le valvole di sicurezza.

Grazie alle proprie consociate, è in grado di produrre una vasta gamma di valvole e raccordi ad alto contenuto tecnologico, sia in ghisa che in plastica: valvole a farfalla, valvole a saracinesca, sfiati, valvole idrauliche, valvole a fuso e giunti di smontaggio. Prodotti questi che possono essere controllati da motori elettrici o attuatori pneumatici.

Il sistema T.I.S. garantisce un pacchetto di soluzioni completo: dalla singola fornitura di apparecchiature alla consulenza di ingegneria attinente le problematiche più complesse dei sistemi idrici. Le principali attività sono: fornitura di apparecchiature idrauliche, automazione, modellazione idraulica delle reti e taratura modelli, ricerca perdite, gestione controllata delle pressioni, efficientamento energetico.

T.I.S. Service offre al cliente un servizio personalizzato, tanto nella fase della selezione delle apparecchiature quanto a livello di assistenza post vendita.

Tutte le aziende T.I.S. sono certificate ISO 9001. Dal 2011 l'Organizzazione vanta la prestigiosa certificazione di Gruppo.

**ENG** T.I.S. SERVICE S.p.A., is a leading international company specializing in the production and sale of equipment for water networks services and for hydroelectric power plants. One of its core products are safety valves.

Thanks to its partners, the company is able to produce a wide range of high technology valves and fittings, both in cast iron and plastic; butterfly valves, gate valves, air release valves, automatic control valves, plunger flow control valves and dismantling joints.

These products can be controlled by electric motors or pneumatic actuators.

The T.I.S. system guarantees a complete solution package: from individual equipment supplies to engineering consultations on the more complex problems of water systems. The company's main activities are: supply of hydraulic equipment, automation, hydraulic network modelling and model calibration, leak detection, controlled pressure management, energy efficiency.

T.I.S. Service offers customers a personalized service, from the equipment selection stage right through to after-sales support.

All T.I.S. companies are certified ISO 9001. The Organization has held the prestigious Group certification since 2011.

**T.I.S.**  
AN ELECTROSTEEL ENTERPRISE

**T.I.S.** SERVICE

**T.I.S.** POLSKA

**T.I.S.** NJUVAL

**T.I.S.** TURKEY

**T.I.S.**  
ENGINEERING

**FRA** T.I.S. SERVICE S.p.A., leader au niveau international, est spécialisée dans la production et la vente d'appareils pour les services de réseau d'eau et pour les centrales hydroélectriques. Les soupapes de sécurité constituent l'un des produits phare.

Grâce à ses entreprises associées, elle est capable de produire une vaste gamme de vannes et de raccords à forte valeur technologique, réalisés en fonte et plastique: vannes-papillons, robinets-vannes, purgeurs, vannes hydrauliques, vannes à pointeau et joints de démontage. Ces produits peuvent être commandés par des moteurs électriques ou des actionneurs pneumatiques.

Le système T.I.S. propose un package complet de solutions : de la fourniture d'appareils à la consultation en ingénierie sur les problématiques les plus complexes des systèmes hydriques. Les principales activités sont la fourniture d'appareils hydrauliques, l'automatisme, la modélisation hydraulique des réseaux et l'étalonnage des modèles, la recherche de fuites, la gestion contrôlée des pressions, l'efficacité énergétique.

T.I.S. Service propose à ses clients un service personnalisé, aussi bien lors de la sélection des appareils qu'au niveau du service après-vente.

Toutes les entreprises T.I.S. sont certifiées ISO 9001. L'organisation jouit depuis 2011 de la prestigieuse certification de Groupe.

**ESP** T.I.S. SERVICE S.p.A., empresa líder a nivel internacional, está especializada en la producción y venta de equipamientos para servicios de red de agua y centrales hidroeléctricas. Uno de sus productos estrella son las válvulas de seguridad.

Gracias a sus propias asociaciones, es capaz de producir una amplia gama de válvulas y conexiones de alto contenido tecnológico, tanto de hierro fundido como de plástico: válvulas de mariposa, válvulas de compuerta, desventadores, válvulas hidráulicas, válvulas de horquilla y juntas de desmontaje. Todos estos productos se pueden controlar mediante motores eléctricos o actuadores neumáticos.

El sistema T.I.S. garantiza un completo paquete de soluciones: desde el simple suministro de equipamiento hasta el asesoramiento a nivel de ingeniería en relación a los problemas más complejos que pueden presentarse en los sistemas hídricos. Las principales actividades son: suministro de equipamiento hidráulico, automatización, modelado hidráulico de las redes y calibrado de los modelos, estudio de pérdidas, gestión controlada de las presiones, mejora del rendimiento energético.

La empresa T.I.S. Service ofrece al cliente un servicio personalizado, tanto en la fase de selección del equipamiento como a nivel de asistencia postventa.

Todas las empresas T.I.S. cuentan con la certificación ISO 9001. Desde el año 2011, la organización dispone de la prestigiosa certificación de Grupo.

## UNI EN ISO 9001

T.I.S. an Electrosteel Enterprise  
T.I.S. Service  
T.I.S. Nuoval  
T.I.S. Polska  
T.I.S. Turkey

## UNI ISO 45001

T.I.S. Service  
T.I.S. Turkey

## UNI EN ISO14001

T.I.S. Service  
T.I.S. Turkey

## UNI EN 14901

T.I.S. Nuoval  
T.I.S. Turkey

## UNI EN 14021

T.I.S. Service

## UNI/PdR 88

T.I.S. Service

### CERTIFICAZIONI DI PRODOTTO E DM 174 KIWA | KIWA PRODUCT AND HYGIENIC CERTIFICATIONS

Saracinesche a cuneo gommato	Resilient seated gate valves
Valvole a farfalla biflangiate a doppio eccentrico	Double flanged double eccentric butterfly valves
Valvole di regolazione a fuso	Plunger flow control valves
Valvole automatiche a membrana	Automatic control valves

### CERTIFICAZIONE DI PRODOTTO ED IGIENE DVGW | DVGW PRODUCT AND HYGIENIC CERTIFICATION

Valvole a farfalla biflangiate a doppio eccentrico	Double flanged double eccentric butterfly valves
--	--

### CERTIFICAZIONI DI PRODOTTO ED IGIENE VIK-HR | VIK-HR PRODUCT AND HYGIENIC CERTIFICATIONS

Saracinesche a cuneo gommato	Resilient seated gate valves
Valvole a farfalla biflangiate a doppio eccentrico	Double flanged double eccentric butterfly valves
Valvole automatiche a membrana	Automatic control valves
Sfiati (a singola, doppia e triplice funzione)	Air release valves (single, double and triple function)
Valvole di ritegno a clapet	Swing check valves
Valvole di ritegno a palla	Ball check valves
Valvole di derivazione	Service valves

### CERTIFICAZIONI DI IGIENE ACS | ACS HYGIENIC CERTIFICATIONS

Saracinesche a cuneo gommato	Resilient seated gate valves
Valvole a farfalla biflangiate a doppio eccentrico	Double flanged double eccentric butterfly valves
Valvole di regolazione a fuso	Plunger flow control valves
Valvole automatiche a membrana	Automatic control valves

### DICHIARAZIONI DI CONFORMITÀ AL DM 174 | DECLARATIONS OF CONFORMITY TO DM 174

Disponibili su richiesta per una ampia gamma di prodotti | Available on request for a wide range of products

### CERTIFICAZIONI DI PRODOTTO IIP | IIP PRODUCT CERTIFICATION

Raccorderia in PE elettrosaldabile e testa a testa | PE buttfusion and electrofusion fittings



ITA Scansiona il QRcode  
per visualizzare tutti i certificati



ENG Scan the QRcode  
to display all the certificates

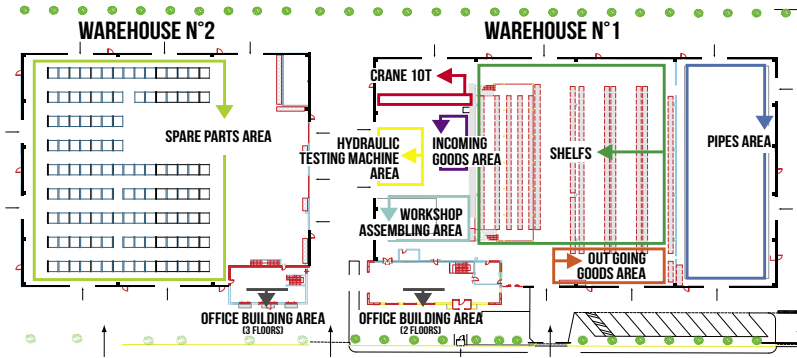

**ITA** La casa madre ha sede a Bolgare, in provincia di Bergamo. L'azienda si sviluppa su una superficie di 20 mila m<sup>2</sup>. I due corpi principali sono collegati a due magazzini, dotati di aree attrezzate per assemblaggio, automazione, collaudo, stoccaggio e movimentazione delle apparecchiature.

**ENG** The parent company is based in Bolgare, in the province of Bergamo. The company covers an area of 20 000 m<sup>2</sup>. The two main buildings are connected to two warehouses, with areas for assembly, automation, testing, storage and equipment handling.

**FRA** La maison mère a son siège à Bolgare, en province de Bergame. La société se développe sur une surface de 20 mille m<sup>2</sup>. Les deux principaux bâtiments sont reliés à deux magasins possédant des zones équipées pour l'assemblage, l'automatisation, le contrôle, le stockage et le déplacement des appareillages. La casa madre tiene sede en Bolgare, en la provincia de Bérgamo.

**ESP** La empresa se desarrolla en una superficie de 20 mil m<sup>2</sup>. Los dos cuerpos principales están comunicados con dos almacenes, dotados de áreas equipadas para el ensamblaje, automatización, pruebas, almacenaje, y movilización de los equipos.

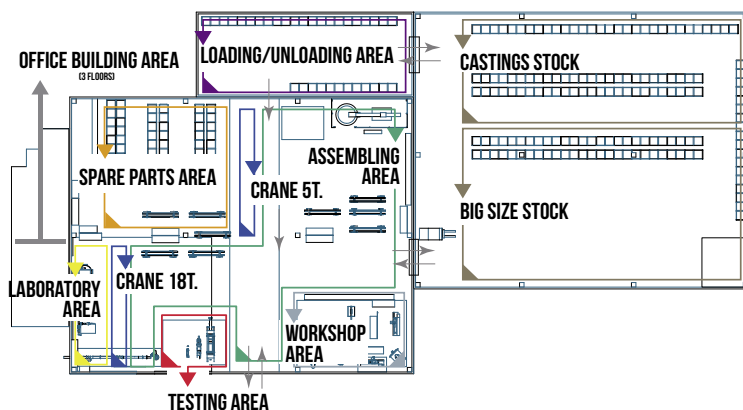

**ITA** T.I.S. Nuoval è la sister company con sede nella provincia di Trento. Polo tecnologico del gruppo, T.I.S. Nuoval trova il suo focus nella ricerca, progettazione e produzione delle apparecchiature idrauliche tra le più innovative sul mercato internazionale.

**ENG** T.I.S. Nuoval, is the sister company based in the province of Trento. The technological centre of the group, T.I.S. Nuoval focus on the research, design and manufacturing of the most innovative hydraulic equipment found on the international market.

**FRA** T.I.S. Nuoval, est la sister company, qui se trouve en province de Trente. Pôle technologique du groupe, T.I.S. Nuoval est concentrée sur la recherche, le projet et la production des appareillages hydrauliques qui font partie des plus innovateurs du marché international.

**ESP** T.I.S. Nuoval, es la sister company con sede en la provincia de Trento. Polo tecnológico del grupo, T.I.S. Nuoval encuentra su enfoque en la búsqueda, proyectación y producción de los equipos hidráulicos entre los más innovadores en el mercado internacional.

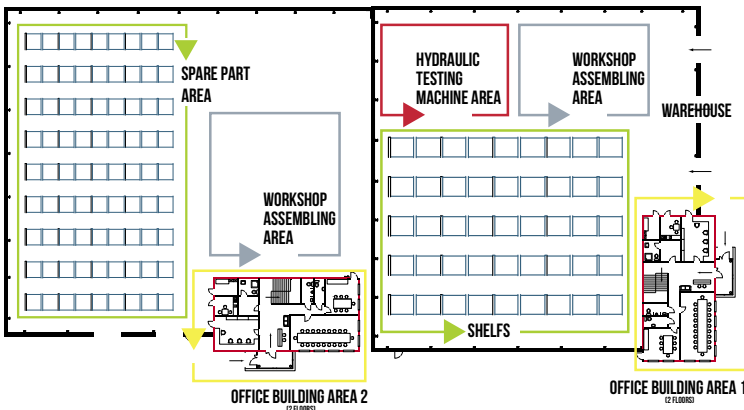

**ITA** T.I.S. Polska è la sister company con sede a Varsavia, in Polonia. Conta su una posizione geografica strategica per gestire le richieste dei mercati dei Paesi del Nord Europa.

**ENG** T.I.S. Polska is the sister company based in Warsaw, Poland. It is situated in a strategic geographical position in order to handle the market demands of Northern Europe.

**FRA** T.I.S. Polska est la sister company, sise à Varsoive, en Pologne. Elle compte sur une position géographique stratégique pour gérer les demandes des marchés des Pays du Nord de l'Europe.

**ESP** T.I.S. Polska es la sister company con sede en Varsavia, Polonia. Cuenta con una posición geográfica estratégica para manejar las solicitudes de los mercados de los Países del Norte de Europa.

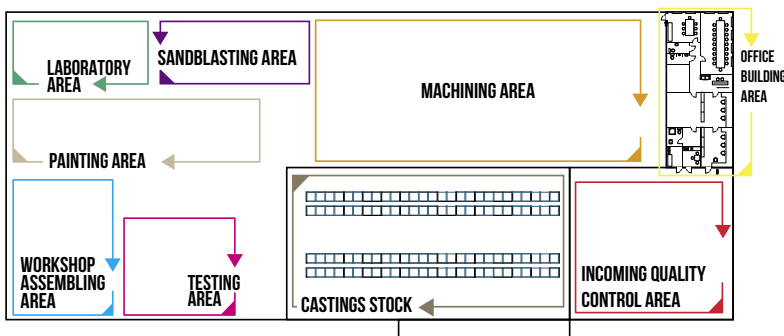

**ITA** T.I.S. Turkey, sister company con sede ad Eskişehir in Turchia, è specializzata nella produzione di valvole a farfalla biflangiate a doppio eccentrico, valvole a saracinesca e sfiati.

**ENG** T.I.S. Turkey, sister company based in Eskişehir, Turkey, is specialized in the production of double flanged double eccentric butterfly valves, gate valves and air release valves.

**FRA** T.I.S. Turkey, sister company basée à Eskişehir, en Turquie, est spécialisée dans la production de vannes à papillon à double extrémité excentriques, robinets-vannes et purgeurs.

**ESP** T.I.S. Turkey, sister company con sede en Eskişehir, Turquía, se especializa en la producción de válvulas de mariposa, válvulas de compuerta y desventadores.

- ITA** Grazie al suo staff di ingegneri specializzati T.I.S. progetta al proprio interno ogni singolo prodotto a proprio marchio.
- ENG** With its staff of specialized engineers T.I.S. designs internally its own brand of each single product.
- FRA** Grâce à ses ingénieurs spécialisés, T.I.S. projette chaque produit portant sa marque, au sein de la société.
- ESP** Gracias a su staff de ingenieros especializados T.I.S. proyecta en su interior propio cada producto con marca propia.

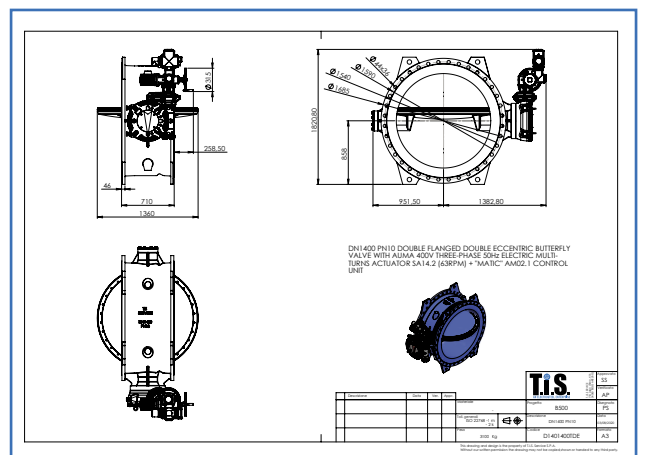
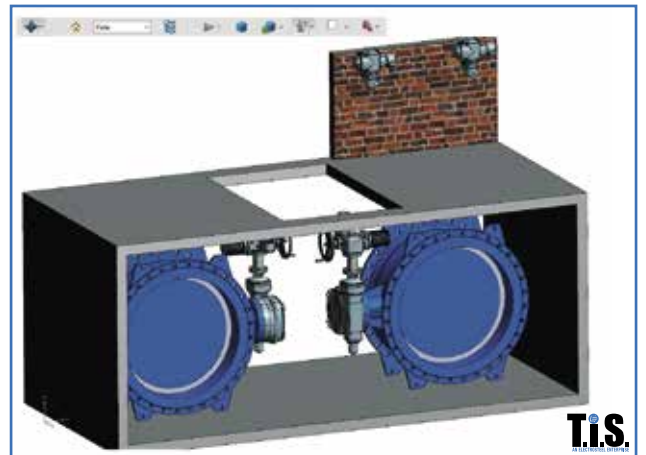
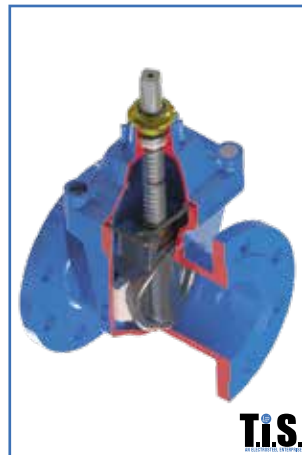
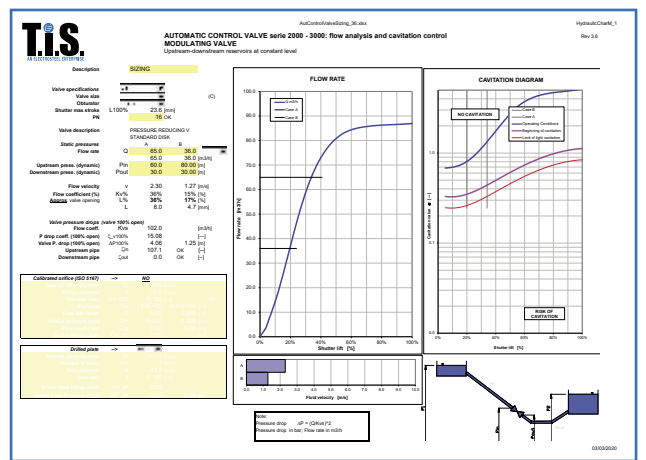
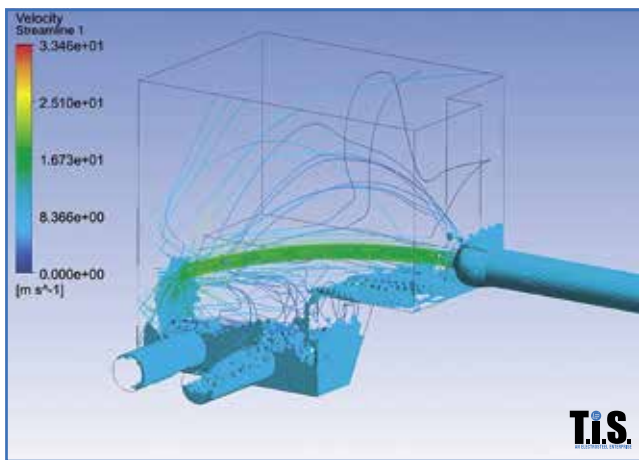

**ITA** All'interno del proprio laboratorio, allestito con le strumentazioni più avanzate, T.I.S. approfondisce la ricerca e lo sviluppo dei prodotti per fornire ai propri clienti qualità e professionalità sempre maggiori.

**ENG** Within its own laboratory, equipped with the most advanced instrumentation, T.I.S. performs in depth research and product development in order to provide its customers with quality and increasing professionalism.

**FRA** A l'intérieur de son laboratoire, équipé des instruments les plus avancés, T.I.S. approfondit la recherche et le développement des produits pour fournir à ses clients, une qualité et une professionnalité toujours plus grandes.

**ESP** Al interior del mismo laboratorio, preparado con la instrumentalización más avanzada, T.I.S. ahonda la búsqueda y el desarrollo de los productos para abastecer a sus propios clientes calidad y profesionalismo siempre mayores.

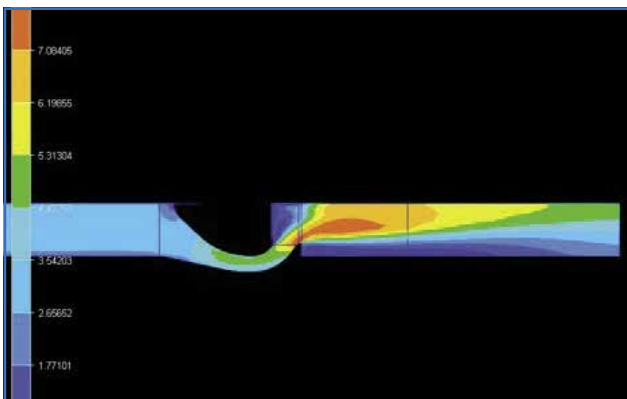
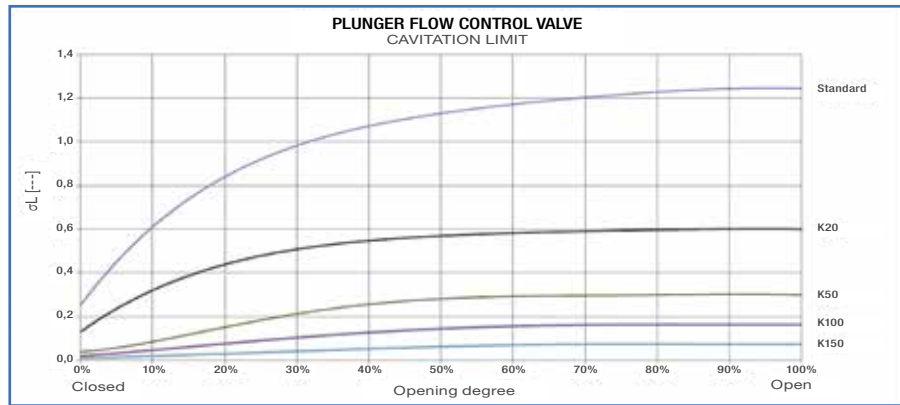

**ITA** Tutta la produzione a marchio T.I.S. è seguita internamente in ogni sua fase dal personale dell'area Controllo Qualità. Lo staff T.I.S. si occupa anche del controllo di tutte le fasi di lavorazione eseguite in outsourcing.

**ENG** The entire T.I.S. brand production is managed internally at every stage by Quality Control staff. T.I.S. staff also handles the monitoring of all the processing stages performed in outsourcing.

**FRA** Toute la production de la marque T.I.S. est suivie à l'intérieur de la société durant chacune de ses phases par le personnel du secteur Contrôle Qualité. L'équipe T.I.S. s'occupe aussi du contrôle de toutes les phases de fabrication effectuées en outsourcing.

**ESP** Toda la producción de marca T.I.S. es seguida internamente en cada fase por el personal del área de Control de Calidad. El staff T.I.S. se ocupa también del control de todas las fases de elaboración ejecutadas en outsourcing.

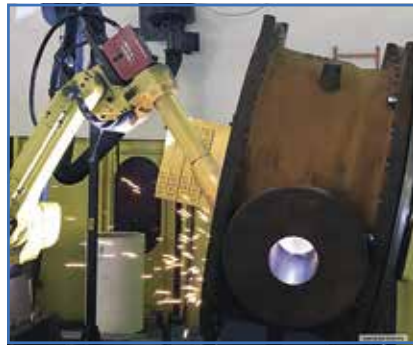



- ITA Ogni singolo prodotto a marchio T.I.S. viene testato con l'utilizzo dei più moderni banchi di prova.
- ENG Each T.I.S. brand product is tested using the most modern testbeds.
- FRA Chaque produit portant la marque T.I.S. est testé sur les bancs de test les plus modernes
- ESP Cada producto de marca T.I.S. es testado con la utilización de los más modernos bancos de pruebas.



# LOGISTIC

- ITA T.I.S. garantisce le consegne del proprio materiale in 48/72 ore in tutta Italia.
- ENG T.I.S. guarantees delivery of their material within 48/72 hours in Italy.
- FRA T.I.S. garantit les livraisons de son matériel en 48/72 heures dans toute l'Italie.
- ESP T.I.S. garantiza las entregas del material en 48/72 horas en toda Italia.



# PROFESSIONAL TRAINING

- ITA T.I.S. è vicina ai propri clienti e rinsalda il rapporto di fiducia con loro organizzando periodicamente corsi e seminari di formazione e specializzazione.
- ENG T.I.S. is close to its customers and strengthens the relationship of trust with them by organizing regular training courses and specialization seminars.
- FRA T.I.S. est proche de ses clients et renforce le rapport de confiance avec eux en organisant périodiquement des cours et des séminaires de formation et de spécialisation.
- ESP T.I.S. está cerca a sus clientes y consolida la relación de confianza con ellos organizando periódicamente cursos y seminarios de formación y especialización.



**ITA** L'esperienza maturata nel settore della regolazione, ha permesso la creazione di un vero e proprio team, il cui compito è intervenire per avviamenti, manutenzioni programmate e straordinarie su tutti gli impianti ove le valvole di regolazione sono installate; tutto ciò sia sul territorio nazionale che su quello internazionale. Obiettivo finale: garantire la continuità del servizio di regolazione.

**ENG** The experience we have accrued in the fluid control industry has allowed us to forge a close-knit team, dedicated to handling plant start-ups as well as scheduled and special maintenance on all systems where control valves are installed, working both nationally and internationally. Our ultimate goal? To guarantee continuity of assistance for all your flow control needs.

**FRA** L'expérience acquise dans le secteur du réglage a permis la création d'une véritable équipe, dont la tâche est d'intervenir pour les mises en route, les entretiens programmés et extraordinaires sur toutes les installations où sont présentes des vannes de réglage, au niveau national et international. L'objectif final: garantir la continuité du service de réglage.

**ESP** La experiencia acumulada en el sector de la regulación ha permitido crear un equipo real y efectivo cuya tarea es intervenir para efectuar arranques, además de mantenimientos programados y extraordinarios, en todas las instalaciones equipadas con las válvulas de regulación; todo ello en territorio tanto nacional como internacional. El objetivo final es garantizar la continuidad del servicio de regulación.



**VALVOLE A FARFALLA BIFLANGIATE E GIUNTI DI SMONTAGGIO**  
**DOUBLE FLANGED BUTTERFLY VALVES & DISMANTLING JOINTS**



**VALVOLE AUTOMATICHE DI CONTROLLO**  
**AUTOMATIC CONTROL VALVES**



**VALVOLE DI REGOLAZIONE A FUSO**  
**PLUNGER FLOW CONTROL VALVES**



**SARACINESCHE A CUNEO GOMMATO**  
**RESILIENT SEATED GATE VALVES**



**SFIATI**  
**AIR RELEASE VALVES**



**VALVOLE DI RITEGNO TILTING**  
**TILTING CHECK VALVES**



**VALVOLE DI DERIVAZIONE**  
**SERVICE VALVES**



**SARACINESCHE A GHIOTTINA E PARATOIE**  
**KNIFE GATE VALVES & PENSTOCKS**

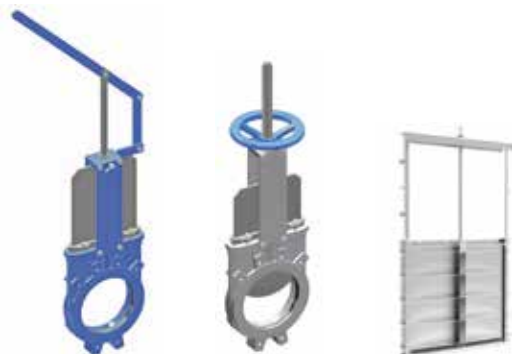

**GIUNTI E COLLARI**  
**PIPE COUPLINGS**



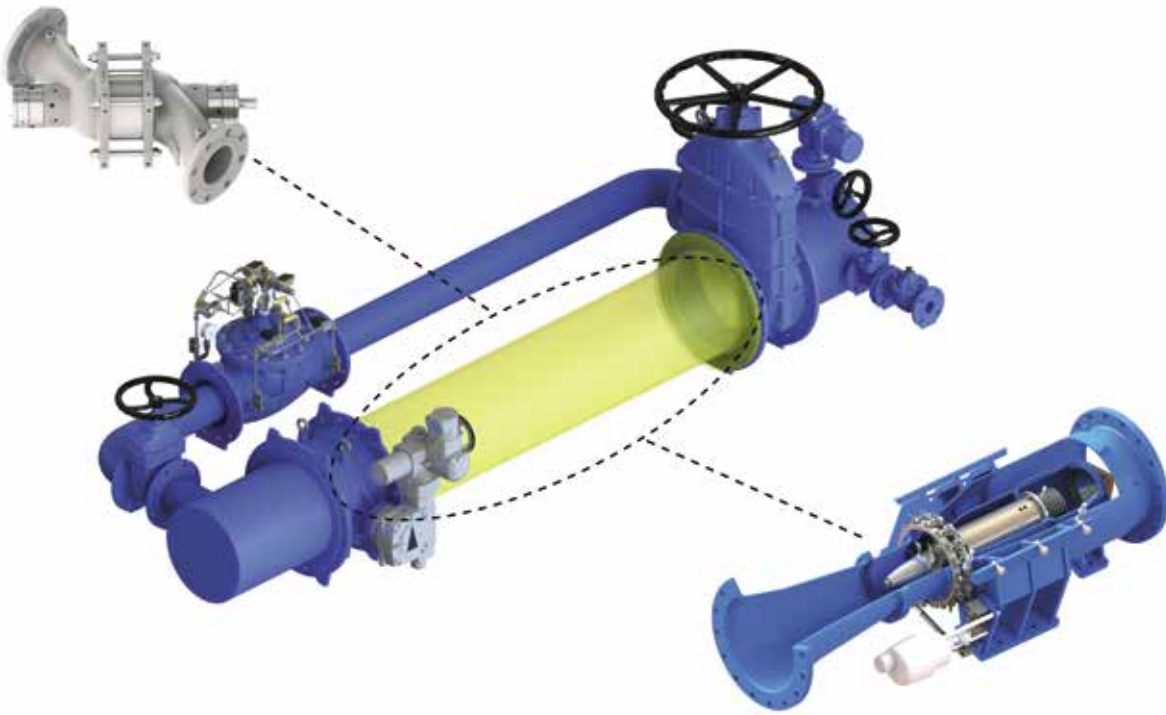

VALVOLE A COMANDO ELETTRICO  
ELECTRIC ACTUATED VALVES



VALVOLE A COMANDO PNEUMATICO  
PNEUMATIC ACTUATED VALVES



VALVOLE A COMANDO IDRAULICO  
HYDRAULIC ACTUATED VALVES



**SARACINESCHE A TENUTA METALLICA  
METAL SEATED GATE VALVES**



**VALVOLE A FARFALLA CENTRICHE  
CENTRIC BUTTERFLY VALVES**



**VALVOLE DI RITEGNO  
CHECK VALVES**



**FILTRI  
STRAINERS**



**GIUNTI DI GOMMA  
RUBBER JOINTS**



**RACCORDERIA IN PE ELETTROSALDABILE E TESTA A TESTA  
PE BUTTFUSION & ELECTROFUSION FITTING**



**RACCORDERIA  
FITTINGS**



# PRESSURE AND LEAKAGE MANAGEMENT

**ITA** T.I.S. Solutions rappresenta un avanzato sistema applicativo studiato per migliorare il rendimento delle reti degli acquedotti. Attraverso un'accurata gestione delle pressioni e delle portate, vengono individuate e ridotte le perdite. I gestori, sfruttando modelli matematici, possono così determinare gli interventi da realizzare. Vantaggi T.I.S. Solutions: ricerca delle perdite mediante manovre STEP-TEST notturne, con verifica sul campo delle valvole di sezionamento e collaudo idraulico dei singoli sottodistretti e gestione controllata delle pressioni mediante inserimento di organi di regolazione.

**ENG** T.I.S. Solutions is an advanced applicative system designed to improve the performance of aqueduct networks. Through careful management of pressures and flow rates, losses are identified and reduced. Managers, using mathematical models, may well determine the necessary actions to be taken. T.I.S. Solutions benefits: leakage detection through night STEP-TEST, with field testing of the isolation valves and hydraulic testing of individual subdistricts and controlled management of pressure by the insertion of regulatory bodies.

**FRA** T.I.S. Solutions représente un système d'application avancé, étudié pour améliorer le rendement des réseaux des aqueducs. A travers une gestion soignée des pressions et des débits, les pertes sont localisées et réduites. Les exploitants, en utilisant des modèles mathématiques, peuvent ainsi déterminer les interventions à réaliser. Avantages de T.I.S. Solutions: recherche des pertes par manoeuvres PAS-A-PAS nocturnes, avec vérification sur le terrain des soupapes d'arrêt et contrôle hydraulique de chaque sous-district et gestion contrôlée des pressions par insertion d'organes de réglage.

**ESP** T.I.S. Solutions representa un avanzado sistema aplicativo estudiado para mejorar el rendimiento de las redes de los acueductos. A través de una esmerada gestión de las presiones y de los alcances vienen individualizadas y reducidas las pérdidas. Los gestores explotando modelos matemáticos, pueden así determinar las intervenciones por realizar. Ventajas T.I.S. Solutions: búsqueda de las pérdidas mediante maniobras STEP-TEST nocturnas, con verificación en el campo de las válvulas de seccionamiento y prueba hidráulica de cada uno de los subdistritos y gestión controlada de las presiones mediante introducción de órganos de regulación.

**NETWORK KNOWLEDGE**



**Data research to build the hydraulic model**

- pipelines,
- water tanks,
- valves and their various operating modes
- pumps and their various characteristics

**INSTRUMENT INSTALLATION**

**Data acquisition:**

- Water Flow
- Pressure



**DISTRICT METERED AREAS**



**DMA (District Metered Areas):** sub-areas for which it is possible to reach

- DMA 1
- DMA 2
- DMA 3
- DMA 4
- DMA 5

**PRESSURE MANAGEMENT**

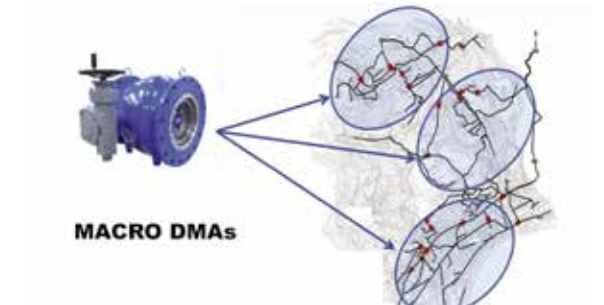

**MACRO DMAs**

## ACTIVE LEAKAGE CONTROL

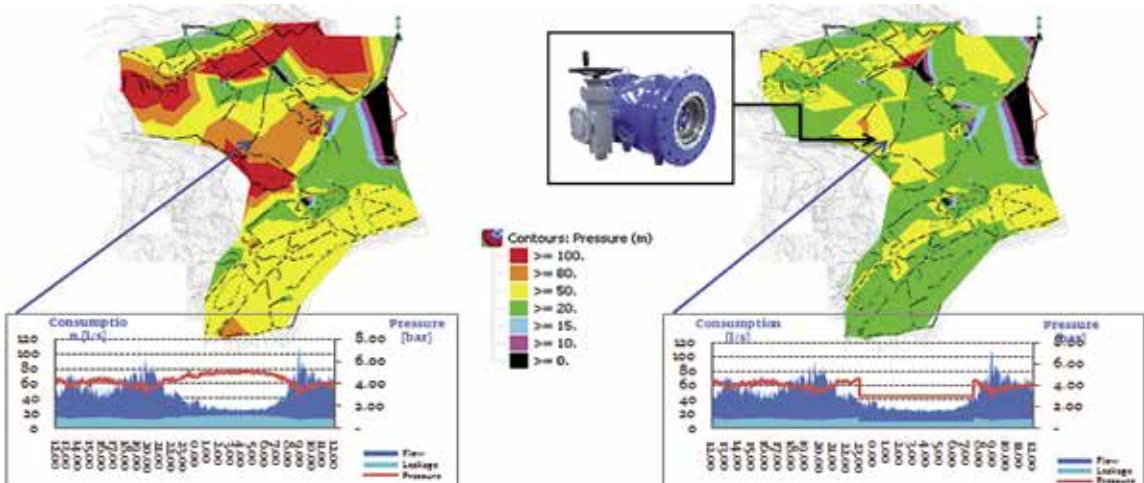



# T.I.S.

AN ELECTROSTEEL ENTERPRISE

**T.I.S.**  
SERVICE

BERGAMO ITALY



**T.I.S.**  
POLSKA

WARSAW POLAND



**T.I.S.**  
NUJOVAL

TRENTO ITALY



**T.I.S.**  
TURKEY

ESKIŞEHİR TURKEY



**T.I.S.**  
ENGINEERING

VARAŽDIN CROATIA



EDITION 01-2026

T.I.S. SERVICE S.P.A.  
VIA LAGO D'ISEO 4,6  
24060 BOLGARE (BG) - ITALY  
TEL. +39 035 8354 811  
FAX +39 035 8354 888  
WWW.TIS-SERVICE.IT  
INFO@TIS-SERVICE.IT



UNI EN ISO 9001:2015  
UNI EN ISO 14001:2015  
UNI ISO 45001:2018

ASSOCIATED



Associazione Italiana costruttori valvole e rubinetteria



Federazione delle Associazioni Nazionali dell'Industria Meccanica Varia ed Affine