



VALVOLA A FARFALLA WAFER DA DN250 A DN600 PN10-PN16
WAFER BUTTERFLY VALVE FROM DN250 TO DN600 PN10-PN16

APPLICAZIONE:

Impianti idrici, riscaldamento, condizionamento e antincendio.

APPLICATION:

Water systems, heating, conditioning and fire prevention.

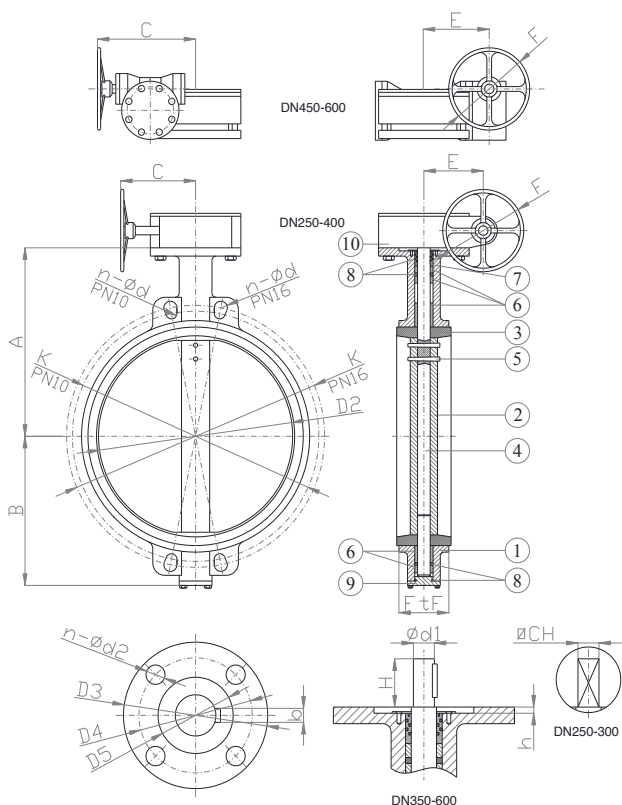

CARATTERISTICHE PRINCIPALI - MAIN FEATURES	
NORMA PROGETTO:	EN 593, EN 1074-1 ed EN 1074-2
SCARTAMENTO:	EN 558 Serie 20
FLANGE:	EN 1092-2
COLLAUDI:	EN 12266-1
FLANGIA SUPERIORE:	ISO 5211
TEMPERATURA ESERCIZIO:	EPDM ≤ +120°C NBR ≤ +80°C
DESIGN STANDARD:	EN 593, EN 1074-1 ed EN 1074-2
FACE TO FACE:	EN 558 Serie 20
FLANGES:	EN 1092-2
TESTS:	EN 12266-1
TOP FLANGE:	ISO 5211
WORKING TEMPERATURE:	EPDM ≤ +120°C NBR ≤ +80°C

	COMPONENTI - PARTS	MATERIALI - MATERIALS
1	CORPO BODY	EN-GJS 400-15 EN-GJS 400-15
2	DISCO DISC	EN-GJS 400-15 (Nichelato) EN-GJS 400-15 (Nickel plated)
3	TENUTA SEAT	GOMMA EPDM (a richiesta NBR) EPDM COATED (NBR on request)
4	ALBERO STEM	ACC.INOX AISI 420 (EN 1.4021) SS AISI 420 (EN 1.4021)
5	PERNO PIN	ACC.INOX AISI 420 (EN 1.4021) SS AISI 420 (EN 1.4021)
6	BOCCOLA BUSHING	FIBRA DI VETRO + PTFE FIBERGLASS + PTFE
7	BOCCOLA DI TENUTA SEAL BUSH	BRONZO/ALLUMINIO ALUMINUM/BRONZE
8	O-RING O-RING	NBR NBR
9	COPERCHIO COVER	EN-GJS 400-15 EN-GJS 400-15
10	RIDUTTORE GEAR BOX	EN-GJL 250 EN-GJL 250

RIVESTIMENTO - COATING	
Esterno con polvere epossidica di colore blu RAL 5015 e spessore 250µm. External FBE coating process with epoxy resin powder of blue colour RAL 5015 and thickness of 250µm.	

DN	K		n-ød		D2	D3	D4	D5	n-ød2	h	CH	ød1	b	H	A	B	C	E	F	FtF	Kv	W (kg)
	PN10	PN16	PN10	PN16																		
250	350	355	12-23	12-28	250	125	102	70	4-12	4	22	-	-	40	292	203	207	66	280	68	4555	30,5
300	400	410	12-23	12-28	301	140	102	70	4-12	4	22	-	-	45	337	242	195	77	280	78	7037	41,5
350	460	470	16-23	16-28	333	150	125	85	4-14	4	-	28	8	52	368	267	195	77	280	78	10165	64,0
400	515	525	16-28	16-31	389	197	140	100	4-18	5	-	36	10	52	400	298	280	120	380	102	13799	74,0
450	565	585	20-28	20-31	440	197	140	100	4-18	5	-	42	12	52	422	317	255	174	285	114	18514	124
500	620	650	20-28	20-34	491	197	140	100	4-18	5	-	42	12	65	480	361	255	174	285	127	23805	149
600	725	770	20-31	20-37	592	276	165	130	4-22	5	-	50	16	70	562	447	280	212	285	154	36778	266