



PN 10 - ART. D158M
PN 16 - ART. D159M



VALVOLA A FARFALLA U-SECTION PN10 O PN16 [DN300 - DN600]
U-SECTION BUTTERFLY VALVE PN10 OR PN16 [DN300 - DN600]

APPLICAZIONE:

Fornitura, raccolta, distribuzione di acqua, reti per la raccolta e deflusso acque di scarico.

APPLICATION:

Water supply and distribution, waste water treatment.

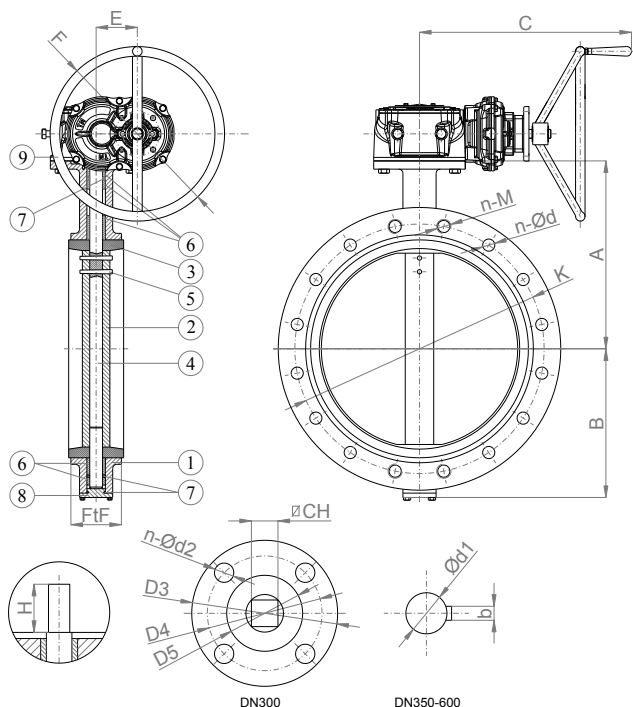

CARATTERISTICHE PRINCIPALI - MAIN FEATURES	
NORMA PROGETTO:	EN 593, EN 1074-1 ed EN 1074-2
SCARTAMENTO:	EN 558 Serie 20
FLANGE:	EN 1092-2 PN10 o PN16
COLLAUDI:	EN 12266-1
FLANGIA SUPERIORE:	ISO 5211
TEMPERATURA ESERCIZIO:	EPDM ≤ +90°C NBR ≤ +70°C
PRESSIONE DI ESERCIZIO:	10 bar - 16 bar
DESIGN STANDARD:	EN 593, EN 1074-1 ed EN 1074-2
FACE TO FACE:	EN 558 Serie 20
FLANGES:	EN 1092-2 PN10 or PN16
TESTS:	EN 12266-1
TOP FLANGE:	ISO 5211
WORKING TEMPERATURE:	EPDM ≤ +90°C NBR ≤ +70°C
WORKING PRESSURE:	10 bar - 16 bar

	COMPONENTI - PARTS	MATERIALI - MATERIALS
1	CORPO BODY	EN-GJS 400-15 EN-GJS 400-15
2	DISCO DISC	INOX AISI 304 SS AISI 304
3	TENUTA SEAT	EPDM (a richiesta NBR) EPDM (NBR on request)
4	ALBERO STEM	ACC. INOX AISI 420 (EN 1.4021) SS AISI 420 (EN 1.4021)
6	BOCCOLA BUSHING	FIBRA DI VETRO + PTFE FIBERGLASS + PTFE
7	O-RING O-RING	EPDM EPDM
8	COPERCHIO COVER	EN-GJS 400-15 EN-GJS 400-15
9	RIDUTTORE GEAR BOX	EN-GJS 400-15 EN-GJS 400-15

Riduttore di sforzo predisposto per attuatore multi-giro con flangia ISO. Gearbox input shaft with ISO top flange for multi-turn actuator coupling.
DN400 - DN600
F10

RIVESTIMENTO - COATING	
Polvere epossidica di colore blu RAL 5015: spessore sul corpo 250µm, disco 400µm. FBE coating with epoxy resin powder of blue colour RAL 5015: thickness on the body 250µm, disc 400µm.	

DN	K		n-od		D3	D4	D5	n-od2	CH	od1	b	H	A	B	C	E	F	FtF	W (kg)
	PN10	PN16	PN10	PN16															
300	400	410	12-23	12-28	140	102	70	4-12	22	-	-	45	337	242	256	55	250	78	38.5
350	460	470	16-23	16-28	150	125	85	4-14	-	28	8	52	368	267	305	64	300	78	79.5
400	515	525	16-28	16-31	197	140	100	4-18	-	36	10	52	400	309	465	56	400	102	86.5
450	565	585	20-28	20-31	197	140	100	4-18	-	42	12	52	422	328	465	56	400	114	128
500	620	650	20-28	20-34	197	140	100	4-18	-	42	12	65	480	361	486	95	400	127	143
600	725	770	20-31	20-37	276	165	130	4-22	-	50	16	70	562	459	500	119	400	154	226