

M3805 • MODULATING ALTITUDE LEVEL CONTROL VALVE

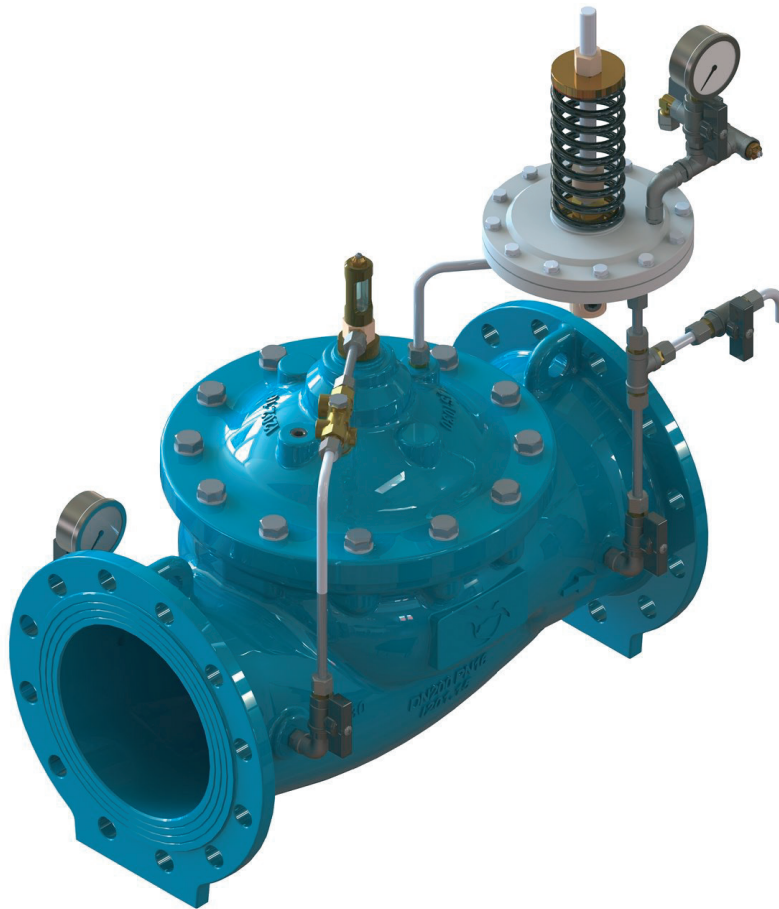

OPERATING PRINCIPLE

The altitude modulating pilot enables the valve to maintain a constant level in a reservoir within a variation range of 10 cm. The combined action of the altitude modulating pilot and the synchronizer machined on the valve stem, ensures an accurate and stable modulation, keeping a balance between the flow required from the network and the flow adducted by the valve into the tank. This type of valve is normally used for tower-tank and for underground reservoirs, where the installation of a conventional float pilot would be complicated or, in some cases, even impossible. Altitude pilot is non-intrusive and doesn't require the installation of any devices inside the reservoir.

ADDITIONAL FUNCTIONS

- pressure sustaining;
- shut-off with electrical remote control;
- non-return;
- reverse flow (for supplying the system through the same pipe in reverse from tower tank to network);
- relief function.

CIRCUIT AND MATERIALS

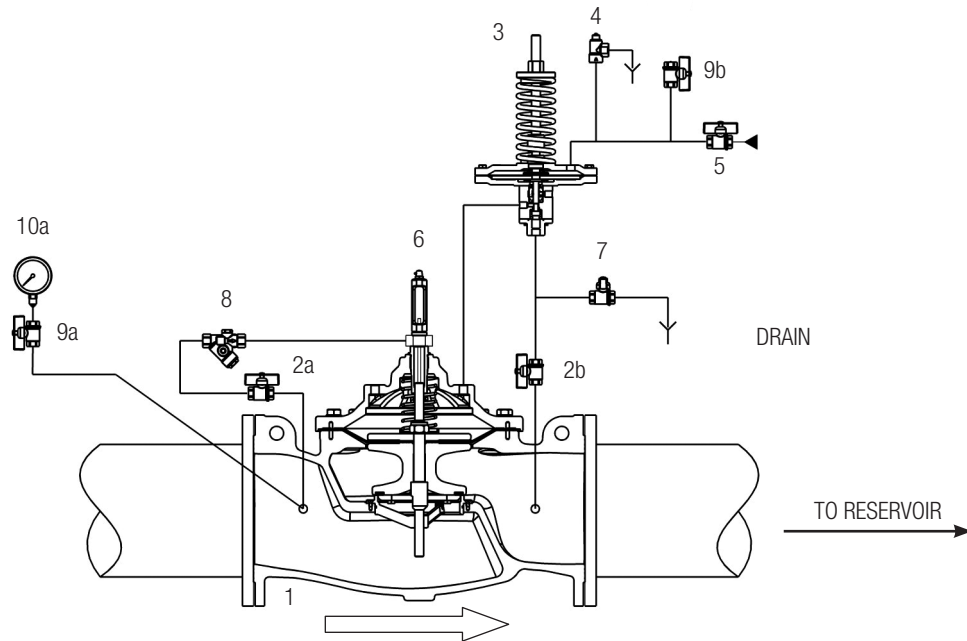

ITEM	DESCRIPTION	MATERIALS (STANDARD)
1	Main valve	GJS400-15 EN1563
2 (a,b)	Isolating ball valve	Ni-plated Brass
3	CL805 modulating altitude pilot	1.4301 EN10088-3
4	Needle valve (drain valve)	1.4401 EN10088-3 + Brass
5	Isolating ball valve for sensing line	Ni-plated Brass
6	Position indicator with manual venting device	Brass + Hardened glass
7	Ball valve for draining to air (NC)	Ni-plated Brass
8	Y-strainer with calibrated orifice	1.4401 EN10088-3 + Brass
9 (a,b)	Gauge holder with drain	Ni-plated Brass
10	Pressure gauge	1.4301 EN10088-3 + Glycerine
--	Pipe	1.4401 EN10088-3
--	Fittings	1.4401 EN10088-3
--	Compression fittings	1.4401 EN10088-3 + Brass

PILOT TABLE RANGE		
PILOT TYPE	AVAILABLE RANGE	RE-OPENING (HYSTERESIS)
CL805A	0.5 - 6 mwh	0.3 mwh
CL805B	3 - 10 mwh	
On request up to 60 mwh (max)		

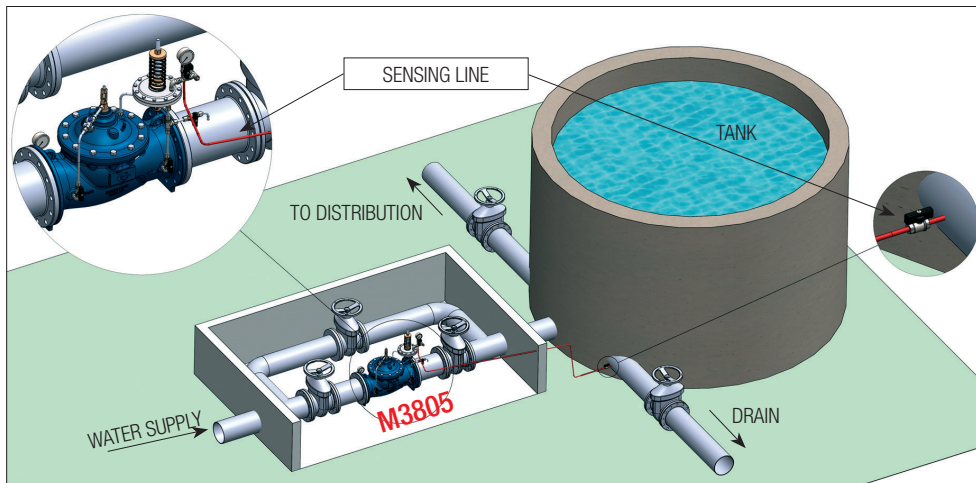

TYPICAL APPLICATION