



**VALVOLA A FARFALLA WAFER DA DN40 A DN200 PN10-PN16 CON RIDUTTORE DI SFORZO**  
**WAFER BUTTERFLY VALVE FROM DN40 TO DN200 PN10-PN16 WITH GEARBOX**

**APPLICAZIONE:**

Fornitura, raccolta, distribuzione di acqua potabile. Impianti idrici, riscaldamento, condizionamento e antincendio.

**APPLICATION:**

Supply, collection, distribution of drinkable water. Water systems, heating, conditioning and fire prevention.

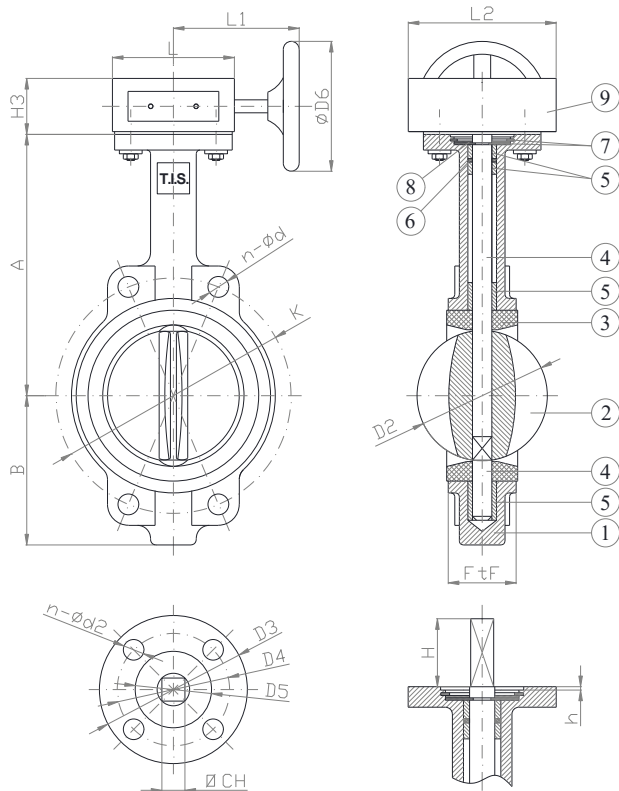

CARATTERISTICHE PRINCIPALI - MAIN FEATURES	
<b>NORMA PROGETTO:</b>	EN 593, EN 1074-1 ed EN 1074-2
<b>SCARTAMENTO:</b>	EN 558 Serie 20
<b>FLANGE:</b>	EN 1092-2
<b>COLLAUDI:</b>	EN 12266-1
<b>FLANGIA SUPERIORE:</b>	ISO 5211
<b>TEMPERATURA ESERCIZIO:</b>	Max. +80°C
<b>DESIGN STANDARD:</b>	EN 593, EN 1074-1 ed EN 1074-2
<b>FACE TO FACE:</b>	EN 558 Serie 20
<b>FLANGES:</b>	EN 1092-2
<b>TESTS:</b>	EN 12266-1
<b>TOP FLANGE:</b>	ISO 5211
<b>WORKING TEMPERATURE:</b>	Max. +80°C

	COMPONENTI - PARTS	MATERIALI - MATERIALS
1	CORPO BODY	EN-GJS 400-15 EN-GJS 400-15
2	DISCO DISC	EN-GJS 400-15 (rivestimento epossidico) EN-GJS 400-15 (Epoxy coated)
3	TENUTA SEAT	GOMMA EPDM (a richiesta NBR) EPDM COATED (NBR on request)
4	ALBERO STEM	ACC. INOX AISI 420 (EN 1.4021) SS AISI 420 (EN 1.4021)
5	BOCCOLA BUSHING	FIBRA DI VETRO + PTFE FIBERGLASS + PTFE
6	O-RING O-RING	NBR NBR
7	SEMI-ANELLO CIRCLIP	ACCIAIO STEEL
8	RONDELLA WASHER	OTTONE BRASS
9	RIDUTTORE GEARBOX	EN-GJL 250 EN-GJL 250

RIVESTIMENTO - COATING	
Polvere epossidica di colore blu RAL 5015: spessore sul corpo 250µm, spessore sul disco 400µm.	
FBE coating with epoxy resin powder of blue colour RAL 5015: thickness on the body 250µm, thickness on the disc 400µm.	

DN	K	n-Ød		D3	D4	D5	ØD6	n-Ød2	h	CH	H	A	B	L	L1	L2	FtF	Kv	W (kg)
		PN10	PN16																
40	110	-	4-19	70	50	35	150	4-7	3	11	32	124	70	105	155	125	33	78	5.6
50	125	-	4-19	90	70	50	150	4-9	4	11	32	161	80	105	155	125	43	98	6.0
65	145	-	4-19	90	70	50	150	4-9	4	11	32	175	89	105	155	125	46	167	6.5
80	160	-	8-19	90	70	50	150	4-9	4	11	32	181	95	105	155	125	46	258	7.0
100	180	-	8-19	90	70	50	150	4-9	4	14	35	200	114	105	155	125	52	512	8.5
125	210	-	8-19	90	70	50	150	4-9	4	14	35	213	127	105	155	125	56	872	9.5
150	240	-	8-23	90	70	50	150	4-9	4	14	35	226	139	105	155	125	56	1347	10.5
200	295	8-23	12-23	125	102	70	250	4-12	4	17	40	260	175	145	240	205	60	2675	21.5