

VALVOLA A FARFALLA WAFER DA DN40 A DN200 PN10-PN16 WAFER BUTTERFLY VALVE FROM DN40 TO DN200 PN10-PN16



APPLICAZIONE:

Fornitura, raccolta, distribuzione di acqua potabile. Impianti idrici, riscaldamento, condizionamento e antincendio.

APPLICATION:

Supply, collection, distribution of drinkable water. Water systems, heating, conditioning and fire prevention.

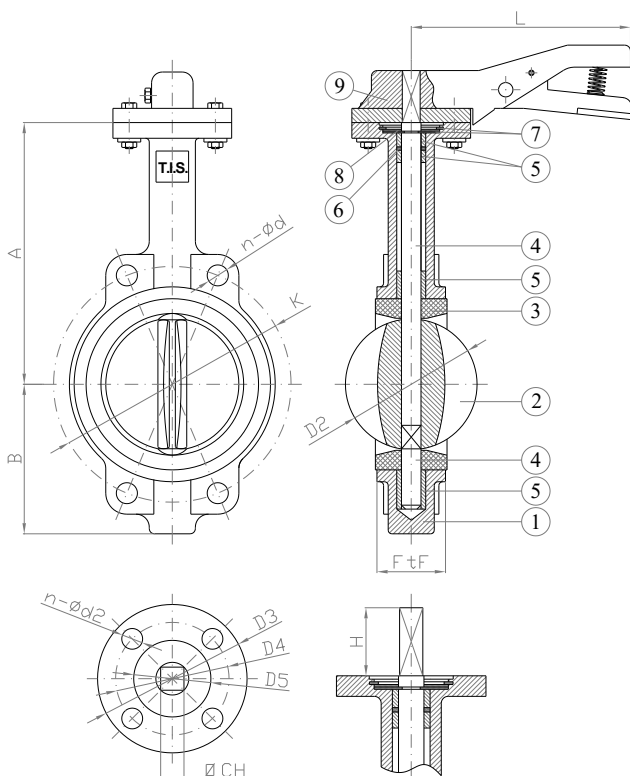

RIVESTIMENTO - COATING

Polvere epossidica di colore blu RAL 5015: spessore sul corpo 250µm, spessore sul disco 400µm.

FBE coating with epoxy resin powder of blue colour RAL 5015: thickness on the body 250µm, thickness on the disc 400µm.

CARATTERISTICHE PRINCIPALI - MAIN FEATURES

NORMA PROGETTO:	EN 593, EN 1074-1 ed EN 1074-2
SCARTAMENTO:	EN 558 Serie 20
FLANGE:	EN 1092-2
COLLAUDI:	EN 12266-1
FLANGIA SUPERIORE:	ISO 5211
TEMPERATURA ESERCIZIO:	Max. +80°C
DESIGN STANDARD:	EN 593, EN 1074-1 ed EN 1074-2
FACE TO FACE:	EN 558 Serie 20
FLANGES:	EN 1092-2
TESTS:	EN 12266-1
TOP FLANGE:	ISO 5211
WORKING TEMPERATURE:	Max. +80°C

	COMPONENTI - PARTS	MATERIALI - MATERIALS
1	CORPO BODY	EN-GJS 400-15 EN-GJS 400-15
2	DISCO DISC	EN-GJS 400-15 (rivestimento epossidico) EN-GJS 400-15 (Epoxy coated)
3	TENUTA SEAT	GOMMA EPDM (a richiesta NBR) EPDM COATED (NBR on request)
4	ALBERO STEM	ACC. INOX AISI 420 (EN 1.4021) SS AISI 420 (EN 1.4021)
5	BOCCOLA BUSHING	FIBRA DI VETRO + PTFE FIBERGLASS + PTFE
6	O-RING O-RING	NBR NBR
7	SEMI-ANELLO CIRCLIP	ACCIAIO STEEL
8	RONDELLA WASHER	OTTONE BRASS
9	LEVA LEVER	EN-GJL 250 EN-GJL 250

DN	K	n-ød		D2	D3	D4	D5	n-ød2	h	CH	H	A	B	L	FtF	Kv	W (kg)
		PN10	PN16														
40	110	-	4-19	43	65	50	35	4-7	3	11	32	140	70	221	33	78	2,6
50	125	-	4-19	53	90	70	50	4-9	4	11	32	161	80	260	43	98	3,4
65	145	-	4-19	65	90	70	50	4-9	4	11	32	175	89	260	46	167	3,9
80	160	-	8-19	79	90	70	50	4-9	4	11	32	181	95	260	46	258	4,3
100	180	-	8-19	105	90	70	50	4-9	4	14	35	200	114	260	52	512	6,6
125	210	-	8-19	124	90	70	50	4-9	4	14	35	213	127	260	56	872	7,7
150	240	-	8-23	156	90	70	50	4-9	4	14	35	226	140	260	56	1347	9,8
200	295	8-23	12-23	203	125	102	70	4-12	4	17	40	260	175	355	60	2675	14,0