

SFIATO DOPPIO GALLEGGIANTE PN10-PN16 AIR RELEASE VALVE DOUBLE CHAMBER PN10-PN16

APPLICAZIONE:

Fornitura, raccolta e distribuzione di acqua.

APPLICATION:

Supply, collection and distribution of water.

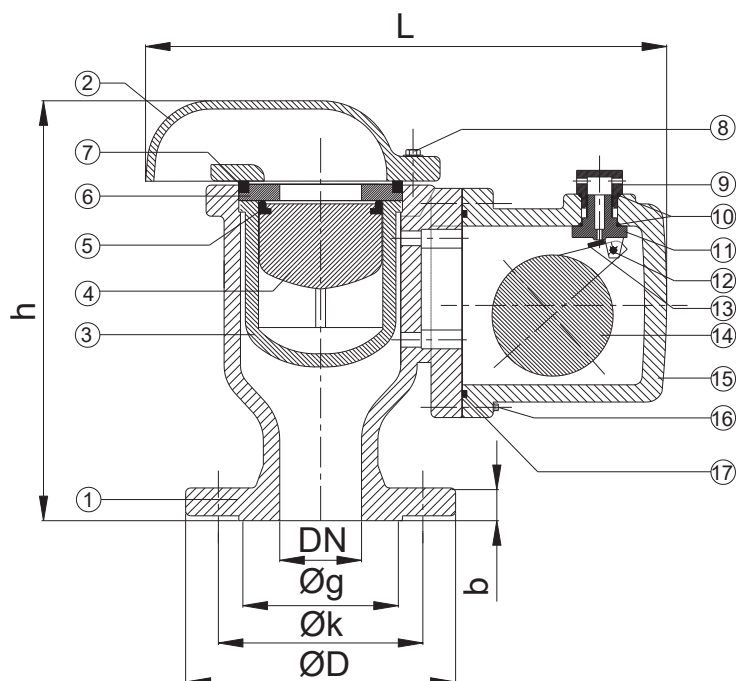

RIVESTIMENTO - COATING

Esterno/interno con polvere epossidica di colore blu RAL 5015 e spessore 250µm.

External/internal FBE coating process with epoxy resin powder of blue colour RAL 5015 and thickness of 250µm.

CARATTERISTICHE PRINCIPALI - MAIN FEATURES

NORMA PROGETTO: EN 1074-1 e EN 1074-4
FLANGE: Foratura secondo EN 1092-2
COLLAUDI: EN 12266-1
TEMP. ESERCIZIO: Max. +80°C
PRESSIONE MIN. DI ESERCIZIO: 0,2 bar

DESIGN STANDARD: EN 1074-1 and EN 1074-4
FLANGES: Drilling according to EN 1092-2
TESTS: EN 12266-1
WORKING TEMP: Max. +80°C
MIN. WORKING PRESSURE: 0,2 bar

	COMPONENTI - PARTS	MATERIALI - MATERIALS
1	CORPO BODY	EN - GJS 400 - 15 EN - GJS 400 - 15
2/15	COPERCHIO COVER	EN - GJS 400 - 15 EN - GJS 400 - 15
3	GABBIA CAGE	POLIAMMIDE 6 POLYAMID 6
4/14	GALLEGGIANTE FLOATER	POLIPROPILENE FOAMED POLYPROPYLENE
5/7 10/17	O-RING O-RING	EPDM EPDM
6	DISCO DISC	OTTONE BRASS
8	VITE E RONDELLA SCREW & WASHER	ACCIAIO 8.8 STEEL 8.8
9/11	DEGASATORE ORIFICE COVER	ACC. INOX AISI 316 S. STEEL AISI 316
12	PIN PIN	ACC. INOX AISI 316 S. STEEL AISI 316
13	TENUTA SEALING FACE	EPDM EPDM
16	VITE SCREW	ACCIAIO 8.8 STEEL 8.8

ART.	E060							E061						
	50	65	80	100	125	150	200	50	65	80	100	125	150	200
DN	50	65	80	100	125	150	200	50	65	80	100	125	150	200
L	325	325	325	370	370	370	370	325	325	325	370	370	370	370
h	260	260	260	320	320	320	450	260	260	260	320	320	320	450
øD	165	185	200	220	250	285	340	165	185	200	220	250	285	340
øk	125	145	160	180	210	240	295	125	145	160	180	210	240	295
øg	99	118	132	156	184	211	266	99	118	132	156	184	211	266
n x ød	4x19	4x19	8x19	8x19	8x19	8x23	8x23	4x19	4x19	8x19	8x19	8x19	8x23	12x23
b	19	19	19	19	19	19	20	19	19	19	19	19	19	20
Viti / Bolt	M16	M16	M16	M16	M16	M20	M20	M16	M16	M16	M16	M16	M20	M20
Peso / weight (kg)	17	20	20.5	31	32	34	64	17	20	20.5	31	32	34	64

PN 25 - ART. E063

PN 40 - ART. E064



SFIATO A DOPPIO GALLEGGIANTE PN25-PN40
AIR RELEASE VALVE DOUBLE CHAMBER PN25-PN40

APPLICAZIONE:

Fornitura, raccolta e distribuzione di acqua.

APPLICATION:

Supply, collection and distribution of water.

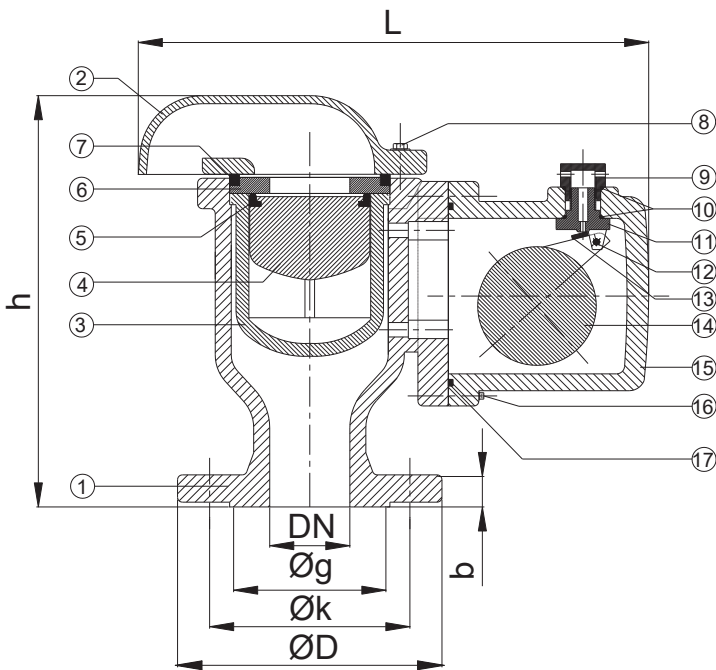

CARATTERISTICHE PRINCIPALI - MAIN FEATURES	
NORMA PROGETTO:	EN 1074-1 e EN 1074-4
FLANGE:	Foratura secondo EN 1092-2
COLLAUDI:	EN 12266-1
TEMP. ESERCIZIO:	Max. +80°C
PRESSIONE MIN. DI ESERCIZIO:	0,2 bar
DESIGN STANDARD:	EN 1074-1 and EN 1074-4
FLANGES:	Drilling according to EN 1092-2
TESTS:	EN 12266-1
WORKING TEMP.:	Max. +80°C
MIN. WORKING PRESSURE:	0,2 bar

RIVESTIMENTO - COATING
Esterno/interno con polvere epossidica di colore blu RAL 5015 e spessore 250µm.
External/internal FBE coating process with epoxy resin powder of blue colour RAL 5015 and thickness of 250µm.

	COMPONENTI - PARTS	MATERIALI - MATERIALS
1	CORPO BODY	EN - GJS 400 - 15 EN - GJS 400 - 15
2/15	COPERCHIO COVER	EN - GJS 400 - 15 EN - GJS 400 - 15
3	GABBIA CAGE	POLIAMMIDE 6 POLYAMID 6
4/14	GALLEGGIANTE FLOATER	POLIPROPILENE FOAMED POLYPROPYLENE
5/7	O-RING	EPDM
10/17	O-RING	EPDM
6	DISCO DISC	OTTONE BRASS
8	VITE E RONDELLA SCREW & WASHER	ACCIAIO 8.8 STEEL 8.8
9/11	DEGASATORE ORIFICE COVER	ACC. INOX AISI 316 S. STEEL AISI 316
12	PIN PIN	ACC. INOX AISI 316 S. STEEL AISI 316
13	TENUTA SEALING FACE	EPDM EPDM
16	VITE SCREW	ACCIAIO 8.8 STEEL 8.8

ART.	E063							E064						
	50	65	80	100	125	150	200	50	65	80	100	125	150	200
DN	50	65	80	100	125	150	200	50	65	80	100	125	150	200
L	325	325	325	370	370	370	370	325	325	325	370	370	370	370
h	260	260	260	320	320	320	450	260	260	260	320	320	320	450
øD	165	185	200	235	270	300	360	165	185	200	235	270	300	375
øk	125	145	160	190	220	250	310	125	145	160	190	220	250	320
øg	99	118	132	156	184	211	274	99	118	132	156	184	211	284
n x ød	4x19	8x19	8x19	8x23	8x28	8x28	12x28	4x19	8x19	8x19	8x23	8x28	8x28	12x31
b	19	19	19	19	19	20	22	19	19	19	19	23.5	26	30
Viti / Bolt	M16	M16	M16	M20	M24	M24	M24	M16	M16	M16	M20	M24	M24	M27
Peso / weight (kg)	17.0	21.0	22.0	34.0	34.5	36.5	67.0	17.0	21.0	22.0	34.0	34.5	36.5	71.0