



**VALVOLA A CLAPET DI FINE LINEA ANTIRIFLUSSO A SEDE TONDA DRITTA  
ROUND MODEL FLAP VALVE**

**APPLICAZIONE:**

anti-riflusso nelle vasche di recupero piovge, reti fognarie o per protezione dalle inondazioni.

**APPLICATION:**

backflow preventer in rain storage reservoirs, sewerage systems or for flood protection purposes.

CARATTERISTICHE PRINCIPALI - MAIN FEATURES

<b>FLANGE:</b>	Per montaggio a parete (parete in accordo alla DIN 18202)	<b>FLANGES:</b>	For wall mounting (wall must be made according to DIN 18202)
<b>TEMP. ESERCIZIO:</b>	Max. +70°C	<b>WORKING TEMP:</b>	Max.+70°C
<b>PRESSIONE MAX. DI ESERCIZIO:</b>	5mca	<b>MAX. OPERATING PRESSURE:</b>	5wmc

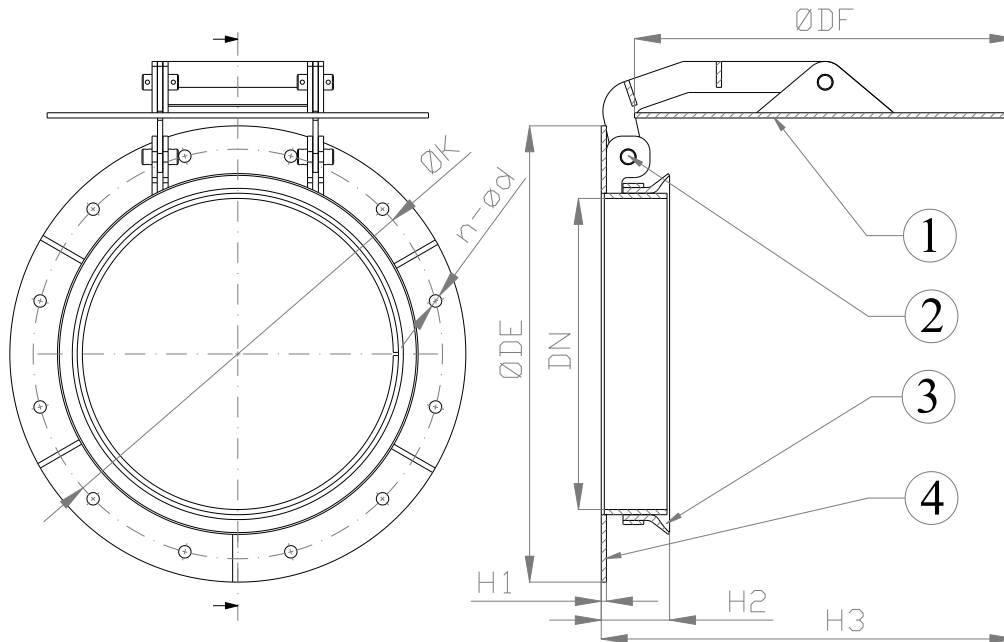

DN	ØDE	ØK	n-Ød	ØDF	H1	H2	H3
200	340	295	8-10	268	5	65.75	285
300	445	400	12-12	368	5	66	400
400	565	515	16-12	468	5	66	509
500	670	620	20-12	568	5	66	607
600	755	705	20-12	668	5	70,5	702
700	860	810	24-12	768	5	70,5	800
800	975	920	24-12	868	5	70,5	895
900	1075	1020	24-12	968	5	70,5	995
1000	1175	1120	28-12	1068	5	73	1080
1100	a richiesta / on request						
1200	1375	1320	32-12	1268	5	74.25	1283

	COMPONENTI - PARTS	MATERIALI - MATERIALS	
		C078ST	C078SST
1	COPERCHIO FLAP	AISI 304 AISI 304	AISI 316 AISI 316
2	ASSE SHAFT	AISI 304 AISI 304	AISI 316 AISI 316
3	TENUTA SEAT	EPDM EPDM	EPDM EPDM
4	TELAIO FRAME	AISI 304 AISI 304	AISI 316 AISI 316

A richiesta: flange forate PN6 / PN10 / PN16 per installazione di fine linea su tubo flangiato in accordo a EN1092.  
On request: flanges drilled PN6 / PN10 / PN16 for end line installation with pipeline flanged according to EN1092.