

M3219 • SURGE ANTICIPATOR / PRESSURE RELIEF VALVE



OPERATING PRINCIPLE

The valve is installed in derivation immediately downstream of a check valve of the pump. When the pump is switched off, the valve is in closed position, and when the pump is switched on, the valve works as a pressure relief valve to protect the system against overpressure caused by the quick-start of the pump.

When a power failure occurs, the valve obturator opens (not completely but regulated) in order to be prepared to relieve the surge against the check valve. Then, the valve obturator will close slowly. The pressure relief function also protects the pump against overheating caused by running in zero flow condition, in this case the valve keeps the pump running at a minimum rate.

The graph shows the effect of water hammering caused by a sudden shutdown of the pump. Surge is the main reason for damages in the system.

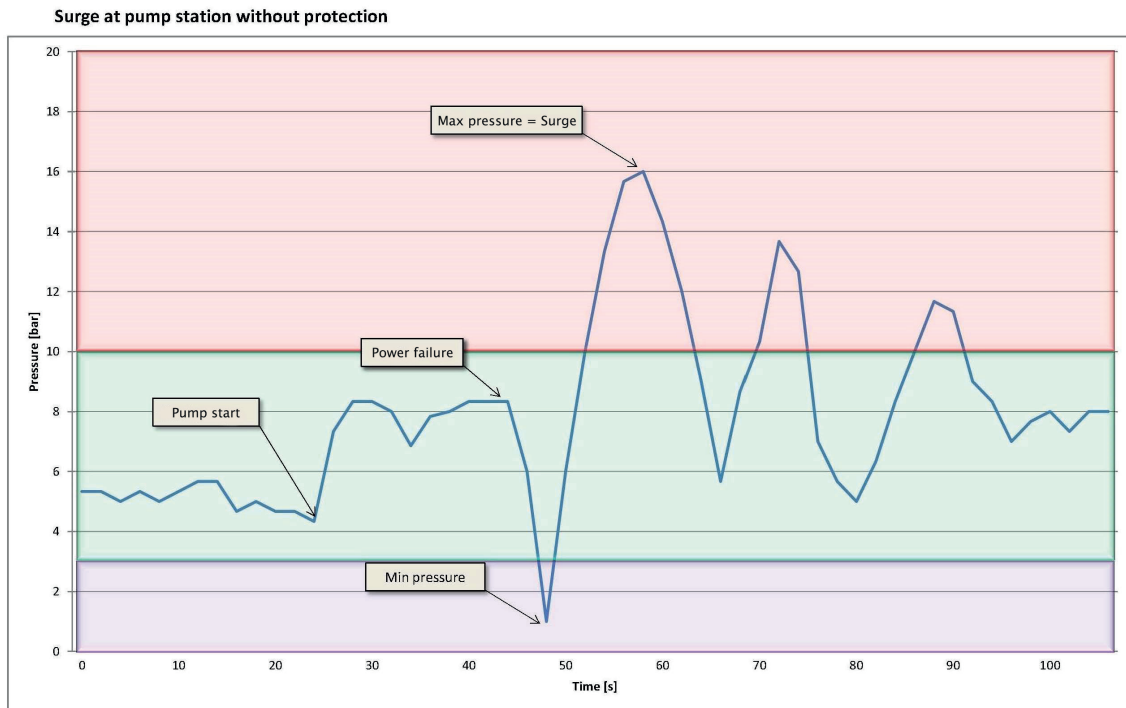

By installing a surge anticipator/pressure relief valve it is possible to reduce strongly the surge effects on the system.

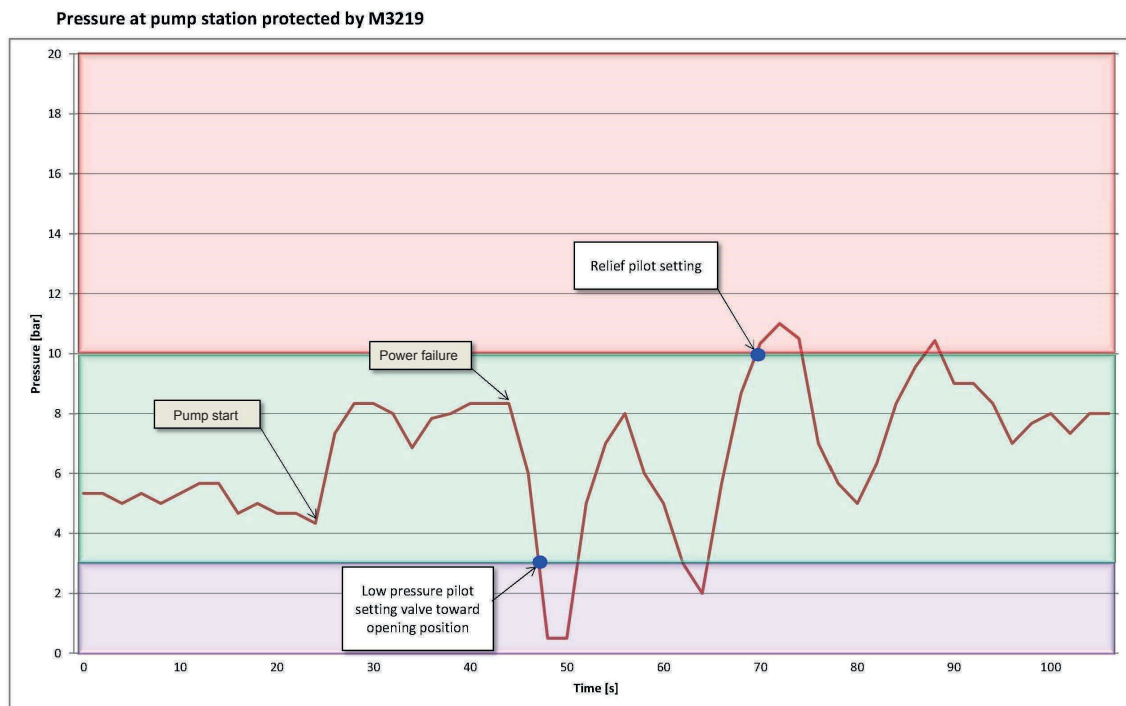

CIRCUIT AND MATERIALS (FROM DN50 TO DN250)

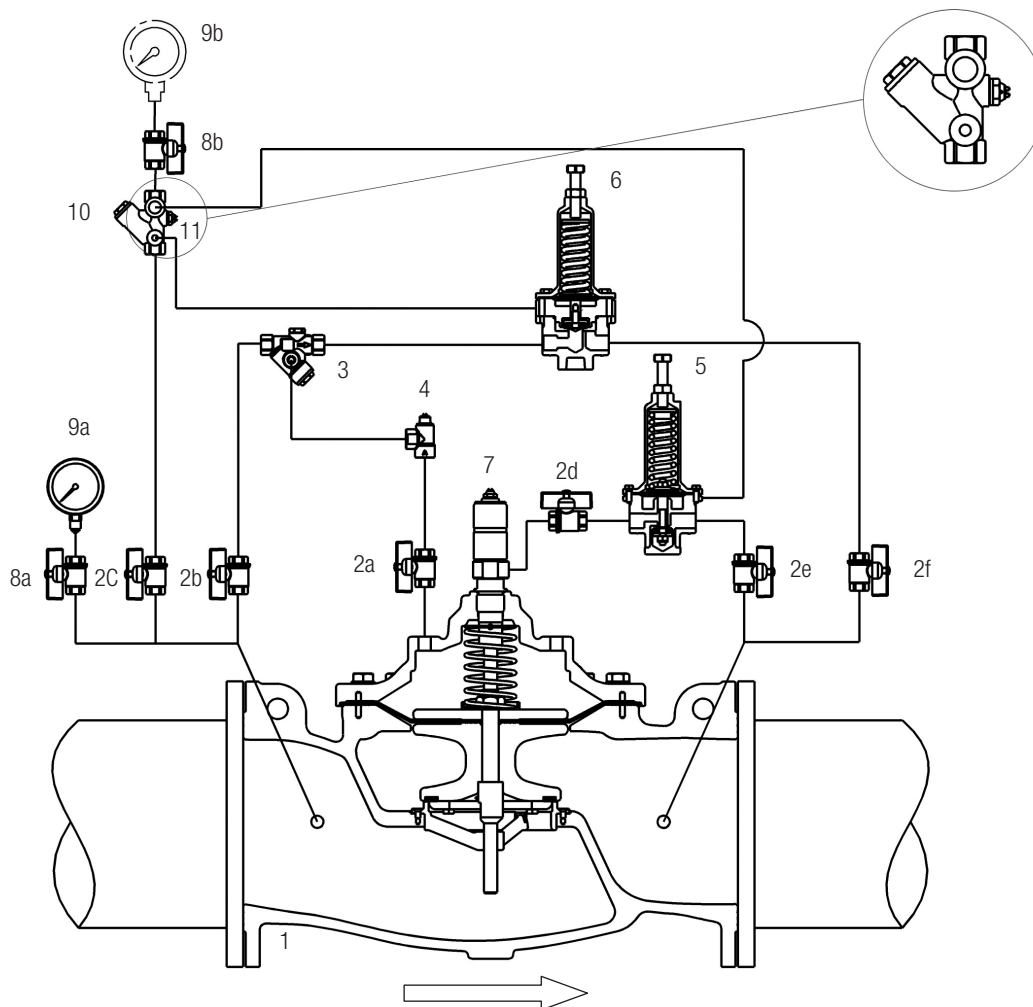

ITEM	DESCRIPTION	MATERIALS (STANDARD)	MATERIAL (HQ / HQ)
1	Main valve	GJS400-15 EN1563	GJS400-15 EN1563
2 (a,b,c,d,e,f)	Isolating ball valve	Ni-plated Brass	HQ: Ni-plated Brass HQ: 1.4401 EN10088-3
3	Y - strainer with calibrated orifice	1.4401 EN10088-3 + Brass	1.4401 EN10088-3
4	Monodirectional needle valve	1.4401 EN10088-3 + Brass	1.4401 EN10088-3
5	Pressure reducer pilot with remote sensing	1.4401 EN10088-3 + Brass (CV100)	1.4401 EN10088-3 (CV160)
6	Pressure relief/sustaining pilot	1.4401 EN10088-3 + Brass (CM200)	1.4401 EN10088-3 (CM260)
7	Flow limiter with manual venting device	Brass+ 1.4301 EN10088-3	1.4401 EN10088-3
8(a,b)	Gauge holder with drainage	Ni-plated Brass	HQ: Ni-plated Brass HQ: 1.4401 EN10088-3
9(a,b)	Pressure gauge	1.4301 EN10088-3 + Glycerine	1.4301 EN10088-3 + Glycerine
10	Y - strainer without orifice	Brass	1.4401 EN10088-3
11	Drain needle valve "test"	1.4301 EN10088-3 + Brass	1.4401 EN10088-3
--	Pipe	1.4401 EN10088-3	1.4401 EN10088-3
--	Fittings	1.4401 EN10088-3	1.4401 EN10088-3
--	Compression fittings	1.4401 EN10088-3 + Brass	1.4401 EN10088-3

CIRCUIT AND MATERIALS (FROM DN300 TO DN600)

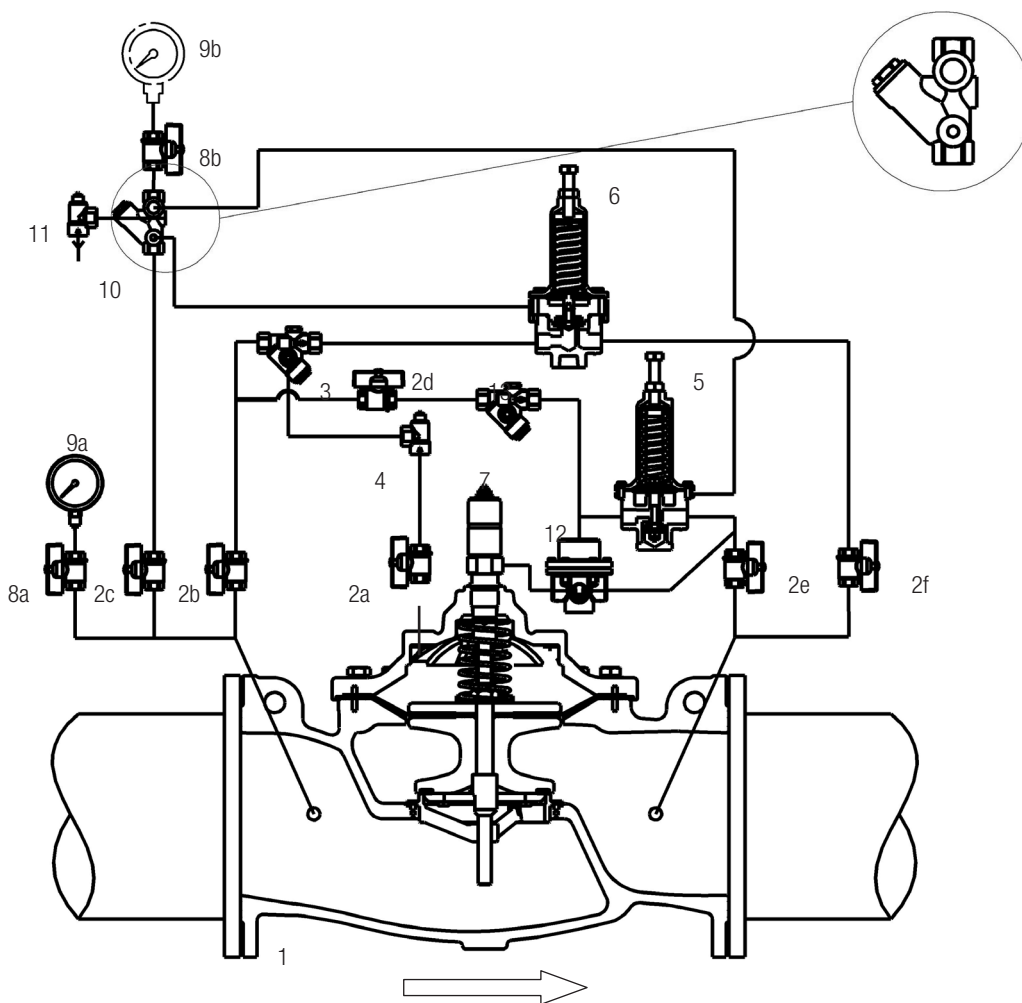

ITEM	DESCRIPTION	MATERIALS (STANDARD)	MATERIALI (HQY / HQ)
1	Main Valve	GJS400-15 EN1563	GJS400-15 EN1563
2 (a,b,c,d,e,f)	Isolating ball valve	Ni-plated Brass	HQY: Ni-plated Brass HQ: 1.4401 EN10088-3
3	Y - strainer with calibrated orifice	1.4401 EN10088-3 + Brass	1.4401 EN10088-3
4	Monodirectional needle valve	1.4401 EN10088-3 + Brass	1.4401 EN10088-3
5	Pressure reducer pilot with remote sensing	1.4401 EN10088-3 + Brass (CV100)	1.4401 EN10088-3 (CV160)
6	Pressure relief/sustaining pilot	1.4401 EN10088-3 + Brass (CM200)	1.4401 EN10088-3 (CM260)
7	Flow limiter with manual venting device	Brass+ 1.4301 EN10088-3	1.4401 EN10088-3
8(a,b)	Gauge holder with drainage	Ni-plated Brass	HQY: Ni-plated Brass HQ: 1.4401 EN10088-3
9(a,b)	Pressure gauge	1.4301 EN10088-3 + Glycerine	1.4301 EN10088-3 + Glycerine
10	Distributor	Brass	1.4401 EN10088-3
11	Bidirectional needle valve "test"	1.4401 EN10088-3 + Brass	1.4401 EN10088-3
12	Auxiliary valve	1.4301 EN10088-3 + Brass (VA200)	1.4301 EN10088-3 (VA260)
13	Y - strainer with calibrated orifice \varnothing 1 mm	1.4401 EN10088-3 + Brass	1.4401 EN10088-3
--	Pipe	1.4401 EN10088-3	1.4401 EN10088-3
--	Fittings	1.4401 EN10088-3	1.4401 EN10088-3
--	Compression fittings	1.4401 EN10088-3 + Brass	1.4401 EN10088-3

TYPICAL APPLICATIONS

