

PN 10 - ART. D112 EPDMQ2M  
 PN 10 - ART. D116 EPDMQ2M  
 PN 16 - ART. D112 EPDMQ216M  
 PN 16 - ART. D116 EPDMQ216M



VALVOLA A FARFALLA LUG DA DN40 A DN200 PN10 O PN16 CON RIDUTTORE DI SFORZO  
 LUG BUTTERFLY VALVE FROM DN40 TO DN200 PN10 OR PN16 WITH GEARBOX

**APPLICAZIONE:**

Fornitura, raccolta, distribuzione di acqua potabile. Impianti idrici, riscaldamento, condizionamento e antincendio.

**APPLICATION:**

Supply, collection, distribution of drinkable water. Water systems, heating, conditioning and fire prevention.

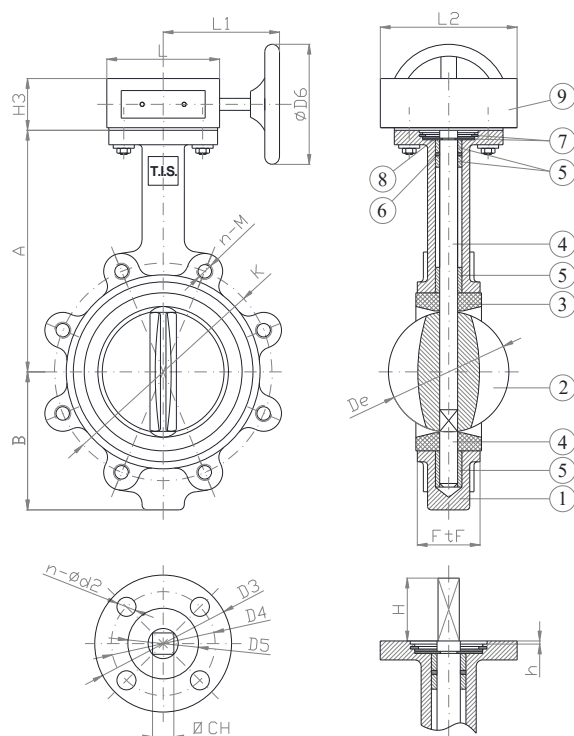

**RIVESTIMENTO - COATING**

Esterno con polvere epossidica di colore blu RAL 5015 e spessore 250µm.

External FBE coating process with epoxy resin powder of blue colour RAL 5015 and thickness of 250µm.

**CARATTERISTICHE PRINCIPALI - MAIN FEATURES**

<b>NORMA PROGETTO:</b>	EN 593, EN 1074-1 ed EN 1074-2
<b>SCARTAMENTO:</b>	EN 558 Serie 20
<b>FLANGE:</b>	EN 1092-2
<b>COLLAUDI:</b>	EN 12266-1
<b>FLANGIA SUPERIORE:</b>	ISO 5211
<b>TEMPERATURA ESERCIZIO:</b>	EPDM ≤ +120°C    NBR ≤ +80°C
<b>DESIGN STANDARD:</b>	EN 593, EN 1074-1 ed EN 1074-2
<b>FACE TO FACE:</b>	EN 558 Serie 20
<b>FLANGES:</b>	EN 1092-2
<b>TESTS:</b>	EN 12266-1
<b>TOP FLANGE:</b>	ISO 5211
<b>WORKING TEMPERATURE:</b>	EPDM ≤ +120°C    NBR ≤ +80°C

	COMPONENTI PARTS	MATERIALI - MATERIALS	
		Art. D112	Art. D116
1	CORPO BODY	ENGJS 400-15 ENGJS 400-15	ENGJS 400-15 ENGJS 400-15
2	DISCO DISC	INOX AISI 316 SS AISI 316	INOX AISI 304 SS AISI 304
3	TENUTA SEAT	GOMMA EPDM (a richiesta NBR) EPDM COATED (NBR on request)	
4	ALBERO STEM	ACC. INOX AISI 420 (EN 1.4021) SS AISI 420 (EN 1.4021)	
5	BOCCOLA BUSHING	FIBRA DI VETRO + PTFE FIBERGLASS + PTFE	
6	O-RING O-RING	NBR NBR	
7	SEMI-ANELLO CIRCLIP	ACCIAIO STEEL	
8	RONDELLA WASHER	OTTONE BRASS	
9	RIDUTTORE GEARBOX	EN-GJL 250 EN-GJL 250	

DN	K	N-M		D3	D4	D5	ØD6	n-ød2	h	CH	H	A	B	L	L1	L2	FtF	Kv	W (kg)
		PN10	PN16																
40	110	-	4-M16	70	50	35	150	4-7	3	11	32	124	70	105	155	125	33	78	7.0
50	125	-	4-M16	90	70	50	150	4-9	4	11	32	161	80	105	155	125	43	98	7.5
65	145	-	4-M16	90	70	50	150	4-9	4	11	32	175	89	105	155	125	46	167	8.0
80	160	-	8-M16	90	70	50	150	4-9	4	11	32	181	95	105	155	125	46	258	9.0
100	180	-	8-M16	90	70	50	150	4-9	4	14	35	200	114	105	155	125	52	512	10.5
125	210	-	8-M16	90	70	50	150	4-9	4	14	35	213	127	105	155	125	56	872	12.0
150	240	-	8-M20	90	70	50	150	4-9	4	14	35	226	139	105	155	125	56	1347	15.0
200	295	8-M20	12-M20	125	102	70	250	4-12	4	17	40	260	175	145	240	205	60	2675	27.0