

## SARACINESCA IN ACCIAIO A VITE INTERNA DA DN200 A DN400 PN63 CAST STEEL GATE VALVE NON RISING STEM FROM DN200 TO DN400 PN63



### APPLICAZIONE:

Fornitura, raccolta, distribuzione di acqua, reti per la raccolta e deflusso acque di scarico, sistemi fognari.

### APPLICATION:

Supply, collection, distribution of water, networks for the collection and discharge of waste water, sewage systems.

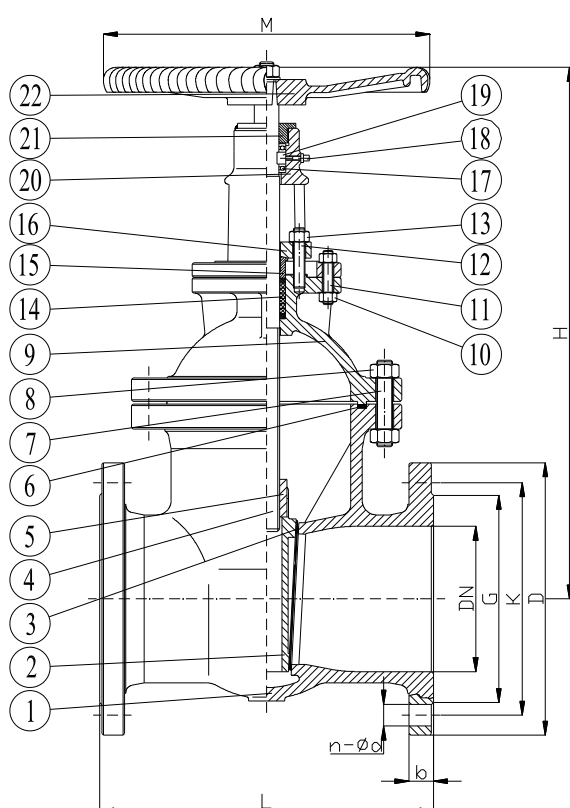

DN	G	K	D	L	H	M	n-ød	b	W (kg)
200	285	345	415	550	744	560	12-36	42	230
250	345	400	470	650	903	640	12-36	46	410
300	410	460	530	750	1003	640	12-36	52	510
350	465	525	600	850	1194	720	16-39	56	780
400	535	585	670	950	1395	800	16-42	60	940

### RIVESTIMENTO - COATING

Esterno/interno con polvere epossidica di colore blu RAL 5015 e spessore 250µm.  
External/internal FBE coating process with epoxy resin powder of blue colour RAL 5015 and thickness of 250µm.

### CARATTERISTICHE PRINCIPALI - MAIN FEATURES

**NORMA PROGETTO:** EN 12516, EN 1984  
**SCARTAMENTO:** EN 558 Serie 26  
**FLANGE:** EN 1092-1  
**COLLAUDI:** EN 12266-1  
**TEMPERATURA ESERCIZIO:** Max. +50°C a 63 bar  
Rapp. pressione/temperatura conforme con EN 12516

**DESIGN STANDARD:** EN 12516, EN 1984  
**FACE TO FACE:** EN 558 Series 26  
**FLANGES:** EN 1092-1  
**TESTS:** EN 12266-1  
**WORKING TEMPERATURE:** Max. +50°C a 63 bar  
Pressure / temperature rating according to EN 12516

	COMPONENTI - PARTS	MATERIALI - MATERIALS
1	CORPO BODY	DIN 17245 GS-C25 DIN 17245 GS-C25
2	CUNEO WEDGE	DIN 17245 GS-C25 DIN 17245 GS-C25
3	TENUTA SEAT	ACCIAIO INOX X10Cr13 SS X10Cr13
4	ASSE STEM	ASTM A182 F6a ASTM A182 F6a
5	MADREVITE STEM NUT	BRONZO ALLUMINIO ALUMINIUM BRONZE
6 / 14	GUARNIZIONE GASKET	ACC. INOX AISI 304+GRAFITE SS AISI 304+GRAPHITE
7 / 10 12	VITE BOLT	ASTM A193 B7 ASTM A193 B7
8 / 11 13	DADO NUT	ASTM A194 2H ASTM A194 2H
9	CAPPELLO BONNET	DIN 17245 GS-C25 DIN 17245 GS-C25
15	ANELLO GLAND	ASTM A182 F6a ASTM A182 F6a
16	PREMISTOPPA PACKING GLAND	DIN 17245 GS-C25 DIN 17245 GS-C25
17	CUSCINETTO BEARING	-- --
18	TAPPO PLUG	OTTONE BRASS
19	ANELLO HOLDING RING	ASTM A276 ASTM A276
20	STAFFA YOKE	DIN 17245 GS-C25 DIN 17245 GS-C25
21	BOCCOLA PACKING	ASTM A1035 ASTM A1035
22	VOLANTINO HANDWHEEL	ASTM A536 ASTM A536