

**BIGIUNTO CON ANTIFILAMENTO PN16**  
**RESTRAINT COUPLING PN16**

**APPLICAZIONE:**

Collegamento di tubi per acqua in PE.

**APPLICATION:**

PE water pipes connections.

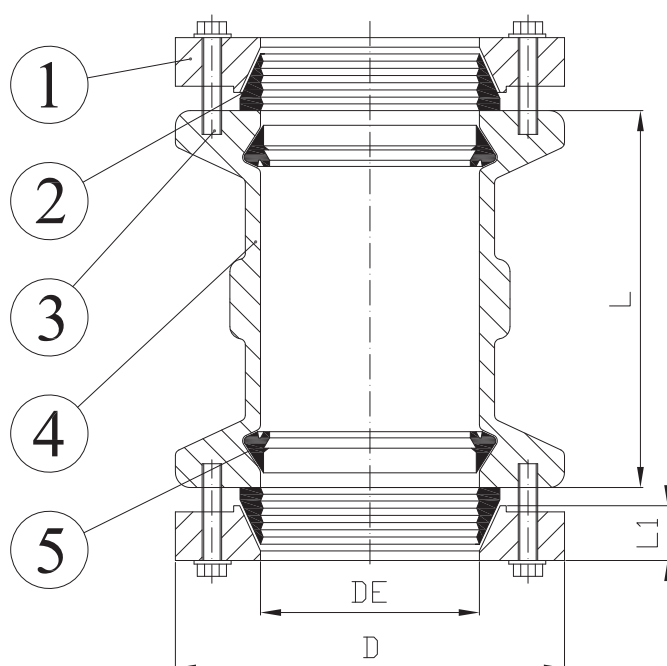

CARATTERISTICHE PRINCIPALI - MAIN FEATURES	
<b>COLLAUDI:</b>	EN 12266-1
<b>PRESSIONE ESERCIZIO:</b>	Max. 16bar
<b>TEMP. ESERCIZIO:</b>	Max. +70°C
<b>COPPIA DI SERRAGGIO:</b>	70Nm da effettuarsi con chiave dinamometrica.
<b>TESTS:</b>	EN 12266-1
<b>WORKING PRESSURE:</b>	Max. 16bar
<b>WORKING TEMP.:</b>	Max. +70°C
<b>TIGHTENING TORQUE:</b>	70Nm to be carried out with dynamometer wrench.

RIVESTIMENTO - COATING	
Esterno/interno con polvere epossidica di colore blu RAL 5010 e spessore 250µm.	
External/internal FBE coating process with epoxy resin powder of blue colour RAL 5010 and thickness of 250µm.	

DE	Viti / Bolts		L (mm)	L1 (mm)	D (mm)	Peso / Weight (kg)
	M	NR.				
75	M10	2	127	15	145	3.5
90	M10	4	127	15	158	4.8
110	M10	4	128	16	180	5.7
125	M10	4	132	18	195	6.1
140	M10	4	145	18	214	7.4
160	M10	4	170	18	235	10.1
180	M10	4	186	19	255	12.2

	COMPONENTI - PARTS	MATERIALI - MATERIALS
1	ANELLO END RING	EN GJS400-15 EN GJS400-15
2	ANELLO ANTIFILAMENTO GRIP RING	OTTONE BRASS
3	VITE E RONDELLA SCREW AND WASHER	ACCIAIO INOX A2-70 STAINLESS STEEL A2-70
4	CORPO BODY	EN GJS400-15 EN GJS400-15
5	GUARNIZIONE GASKET	EPDM EPDM