



PN 10/16 - ART. D112 EPDM Q2 • PN 10/16 - ART. D116 EPDM Q2
 PN 10/16 - ART. D112 NBR Q2 • PN 10/16 - ART. D116 NBR Q2

VALVOLA A FARFALLA LUG DA DN40 A DN200 PN10-PN16
 LUG BUTTERFLY VALVE FROM DN40 TO DN200 PN10-PN16



APPLICAZIONE:

Impianti idrici, riscaldamento, condizionamento e antincendio.

APPLICATION:

Water systems, heating, conditioning and fire prevention.

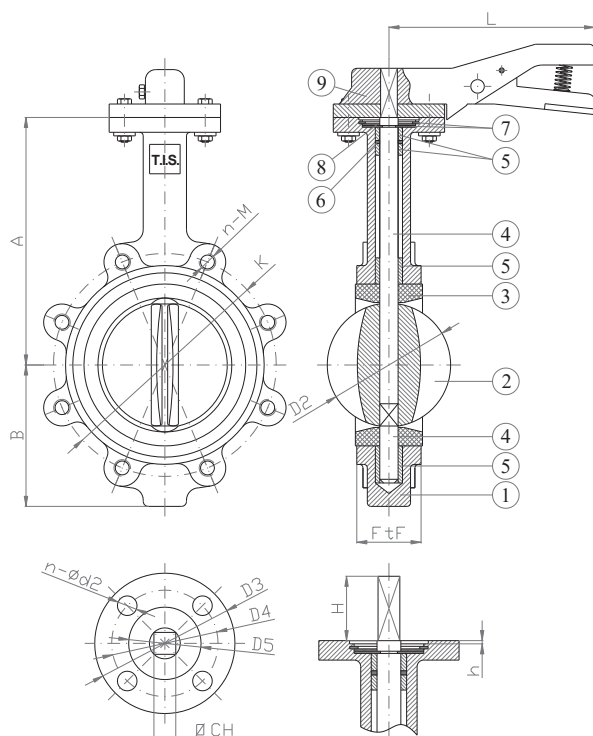

CARATTERISTICHE PRINCIPALI - MAIN FEATURES

NORMA PROGETTO:	EN 593, EN 1074-1 ed EN 1074-2
SCARTAMENTO:	EN 558 Serie 20
FLANGE:	EN 1092-2
COLLAUDI:	EN 12266-1
FLANGIA SUPERIORE:	ISO 5211
TEMPERATURA ESERCIZIO:	EPDM ≤ +120°C NBR ≤ +80°C
DESIGN STANDARD:	EN 593, EN 1074-1 ed EN 1074-2
FACE TO FACE:	EN 558 Serie 20
FLANGES:	EN 1092-2
TESTS:	EN 12266-1
TOP FLANGE:	ISO 5211
WORKING TEMPERATURE:	EPDM ≤ +120°C NBR ≤ +80°C

	COMPONENTI PARTS	MATERIALI MATERIALS	
		Art. D112	Art. D116
1	CORPO BODY	EN-GJS 400-15 EN-GJS 400-15	EN-GJS 400-15 EN-GJS 400-15
2	DISCO DISC	INOX AISI 316 SS AISI 316	INOX AISI 304 SS AISI 304
3	TENUTA SEAT	GOMMA EPDM (a richiesta NBR) EPDM COATED (NBR on request)	
4	ALBERO STEM	ACC. INOX AISI 420 (EN 1.4021) SS AISI 420 (EN 1.4021)	
5	BOCCOLA BUSHING	FIBRA DI VETRO + PTFE FIBERGLASS + PTFE	
6	O-RING O-RING	NBR NBR	
7	SEMI-ANELLO CIRCLIP	ACCIAIO STEEL	
8	RONDELLA WASHER	OTTONE BRASS	
9	LEVA LEVER	EN-GJL 250 EN-GJL 250	

RIVESTIMENTO - COATING

Esterno con polvere epossidica di colore blu RAL 5015 e spessore 250µm.

External FBE coating process with epoxy resin powder of blue colour RAL 5015 and thickness of 250µm.

DN	K	n-ød		D2	D3	D4	D5	n-ød2	h	CH	H	A	B	L	FtF	Kv	W (kg)
		PN10	PN16														
40	110	4-M16	4-M16	43	65	50	35	4-7	3	11	32	140	70	221	33	78	3,0
50	125	4-M16	4-M16	53	90	70	50	4-9	4	11	32	161	80	260	43	98	4,0
65	145	4-M16	4-M16	65	90	70	50	4-9	4	11	32	175	89	260	46	167	4,7
80	160	8-M16	8-M16	79	90	70	50	4-9	4	11	32	181	95	260	46	258	5,5
100	180	8-M16	8-M16	105	90	70	50	4-9	4	14	35	200	114	260	52	512	7,8
125	210	8-M16	8-M16	124	90	70	50	4-9	4	14	35	213	127	260	56	872	10,5
150	240	8-M20	8-M20	156	90	70	50	4-9	4	14	35	226	140	260	56	1347	11,7
200	295	8-M20	12-M20	203	125	102	70	4-12	4	17	40	260	175	355	60	2675	18,0