



PRZEPUSTNICA MIĘDZYKOŁNIERZOWA TYP WAFER OD DN40 DO DN200 PN10-PN16

WAFER BUTTERFLY VALVE FROM DN40 TO DN200 PN10-PN16

ZASTOSOWANIE:

Systemy przesyłu wody, ciepłownictwa, klimatyzacji i przeciwpożarowe.

APPLICATION:

Water systems, heating, conditioning and fire prevention.

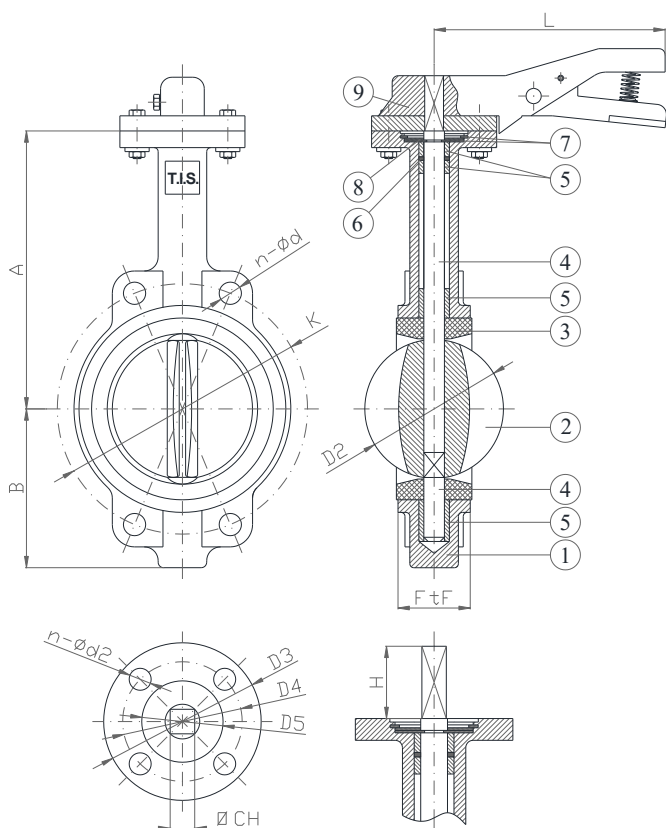

POWŁOKA ANTYKOROZYJNA - COATING

Zewnętrzna powłoka epoksydowa w kolorze niebieskim RAL 5015 o grubości min. 250 µm.
External FBE coating process with epoxy resin powder of blue colour RAL 5015 and thickness of 250µm.

CECHY PRODUKTU - MAIN FEATURES

WYKONANIE:	EN 593, EN 1074-1, EN 1074-2
DŁUGOŚĆ ZABUDOWY:	EN 558 Szereg 20
KOŁNIERZE:	EN 1092-2
PRÓBY:	EN 12266-1
KOŁNIERZ POD NAPĘD:	ISO 5211
TEMPERATURA ROBOCZA:	EPDM ≤ +120°C NBR ≤ +80°C
DESIGN STANDARD:	EN 593, EN 1074-1, EN 1074-2
FACE TO FACE:	EN 558 Serie 20
FLANGES:	EN 1092-2
TESTS:	EN 12266-1
TOP FLANGE:	ISO 5211
WORKING TEMPERATURE:	EPDM ≤ +120°C NBR ≤ +80°C

CZĘŚCI PARTS		MATERIAŁY MATERIALS
		Art. D102
1	KORPUS BODY	EN-GJS 400-15 EN-GJS 400-15
2	DYSK DISC	EN 1.4408 (AISI 316) EN 1.4408 (SS AISI 316)
3	MANSZETA SEAT	EPDM (na życzenie NBR) EPDM COATED (NBR on request)
4	TRZPIEŃ STEM	EN 1.4021 (AISI 420) EN 1.4021 (SS AISI 420)
5	TULEJA BUSHING	WŁÓKNO SZKLANE + PTFE FIBERGLASS + PTFE
6	O-RING O-RING	NBR NBR
7	PIERŚCIEŃ SEGERA CIRCLIP	STAL STEEL
8	PODKŁADKA WASHER	MOSIĄDZ BRASS
9	DŹWIGNIA LEVER	EN-GJL 250 EN-GJL 250

DN	K	n-ød		D2	D3	D4	D5	n-ød2	h	CH	H	A	B	L	FtF	Kv	W (kg)
		PN10	PN16														
40	110	4-19	4-19	43	65	50	35	4-7	3	11	32	140	70	221	33	78	2,6
50	125	4-19	4-19	53	90	70	50	4-9	4	11	32	161	80	260	43	98	3,4
65	145	4-19	4-19	65	90	70	50	4-9	4	11	32	175	89	260	46	167	3,9
80	160	4-19	8-19	79	90	70	50	4-9	4	11	32	181	95	260	46	258	4,3
100	180	8-19	8-19	105	90	70	50	4-9	4	14	35	200	114	260	52	512	6,6
125	210	8-19	8-19	124	90	70	50	4-9	4	14	35	213	127	260	56	872	7,7
150	240	8-23	8-23	156	90	70	50	4-9	4	14	35	226	140	260	56	1347	9,8
200	295	8-23	12-23	203	125	102	70	4-12	4	17	40	260	175	355	60	2675	14,0