

Art. 038016

MANICOTTO ELETTRISALDABILE, PE 100, SDR 11

ELECTROFUSION COUPLER, PE 100, SDR 11

APPLICAZIONE:

Impianti di acquedottistica, di convogliamento gas combustibili, di fognature civili ed industriali, di irrigazione etc...

APPLICATION:

Water pipeline systems, for gas, civil and industrial sewerage, irrigation etc...

NORME PRODOTTO:

UNI EN ISO 15494
UNI EN 1555-3
UNI EN 12201-3

PRODUCT STANDARS:

UNI EN ISO 15494
UNI EN 1555-3
UNI EN 12201-3

TEMPERATURA DI ESERCIZIO:

da -40 a +60°C

WORKING TEMPERATURE:

from -40 to +60°C

PRESSIONE DI ESERCIZIO MAX:

Acqua 16 bar
Gas 5 bar

MAX WORKING PRESSURE:

Water 16 bar
Gas 5 bar

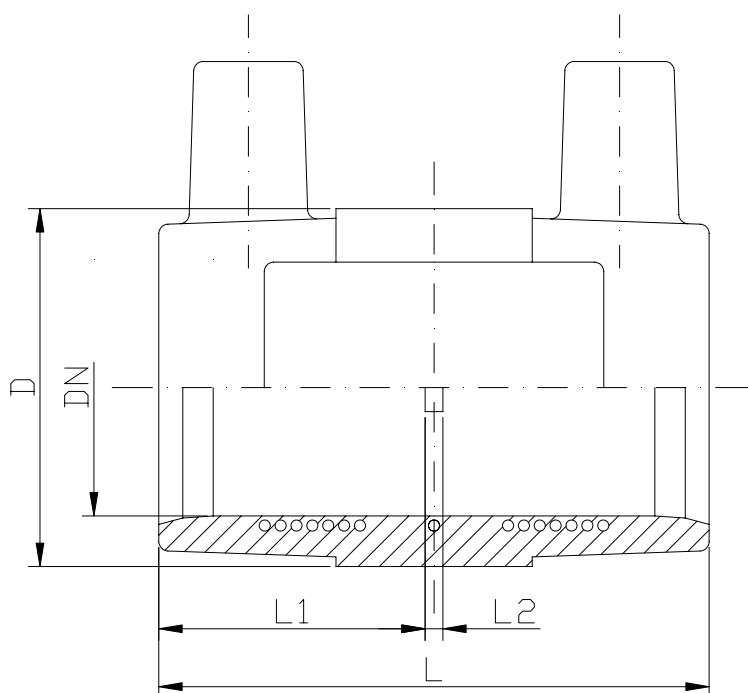

DN	20	25	32	40	50	63	75	90	110	125	140	160	180	200	225	250	280	315	355	400	450	500	
D	36	36	44	57	67	82	100	115	138	150.5	170	190	215	240	280	315	355	400	450	500	555	600	
L1	41	41	42.5	43.5	42	54.5	62.5	66	77.5	82	87	88.5	99.5	99.5	90	110	110	110	130	145	170	180	
L2	3	3	1	1	3	2	3	2	3	3	2	3	3	3	-	-	-	-	-	-	-	-	
L	85	85	86	88	87	111	128	134	158	167	176	180	202	202	180	220	220	220	220	260	290	340	360