

BIGIUNTO UNIVERSALE
UNIVERSAL COUPLING

APPLICAZIONE:

Collegamento di tubi per acqua in acciaio e ghisa di diverso diametro esterno.

APPLICATION:

Steel and ductile iron water pipes connettions.

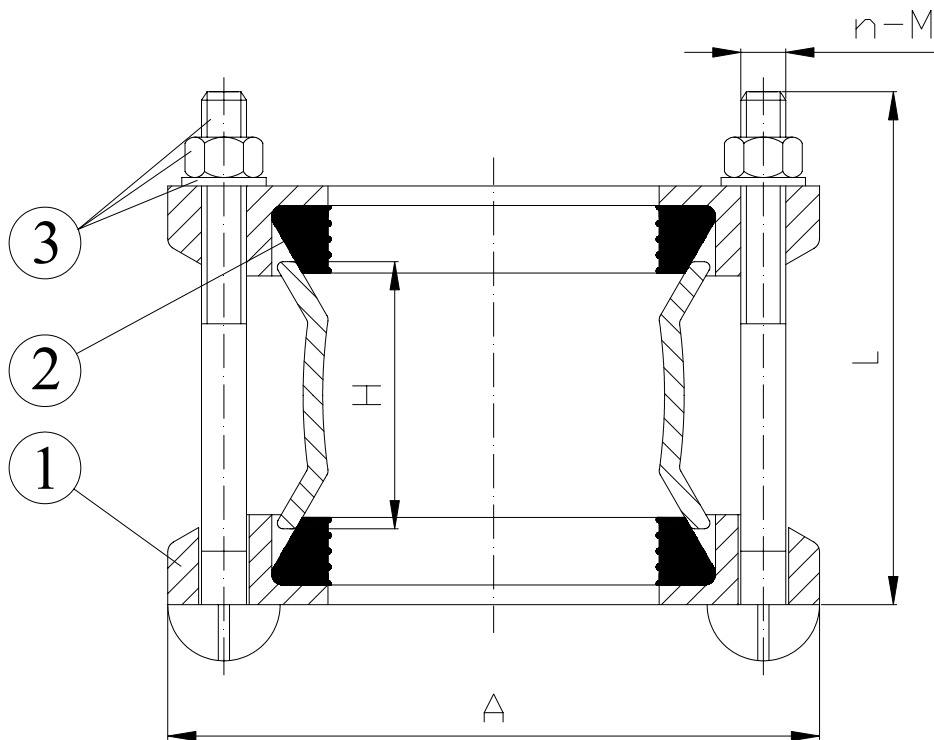
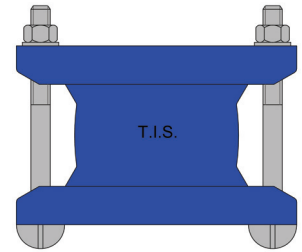

DENOMINAZIONE
PART

MATERIALI
MATERIALS

1	CORPO BODY	GHISA SFEROIDALE DUCTILE IRON
2	GUARNIZIONE GASKET	EPDM EPDM
3	VITE, DADO, RONDELLA SCREW, NUT, WASHER	ACCIAIO STEEL

DN	RANGE	A	H	L	n-M
50	59-72	155	95	180	2-M12
65	72-85	170	95	180	2-M12
80	88-103	185	95	180	4-M12
100	109-128	215	95	180	4-M12
125	138-153	240	95	200	4-M12
150	159-182	275	105	210	4-M12
200	218-235	320	130	220	4-M12
250	272-289	380	130	225	6-M12
300	315-332	423	130	225	6-M12

RIVESTIMENTO ESTERNO/INTERNO: Polvere epossidica di colore BLU RAL 5005 con spessore min 250 μ m.

SURFACE PROTECTION: FBE coating process with epoxy resin powder of sky blue color RAL 5005 and minimum thickness of 250 μ m.

GIUNTO UNIVERSALE FLANGIATO PN 10/16

FLANGE ADAPTER, FLANGED PN 10/16

APPLICAZIONE:

Collegamento di tubi per acqua in acciaio e ghisa di diverso diametro esterno.

APPLICATION:

Steel and ductile iron water pipes connettions.

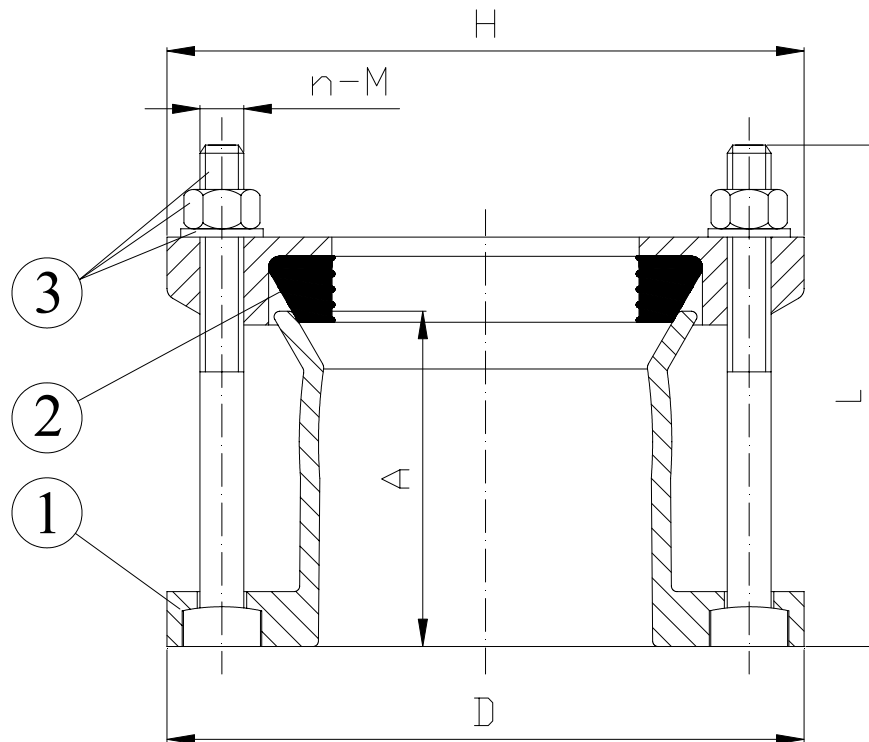
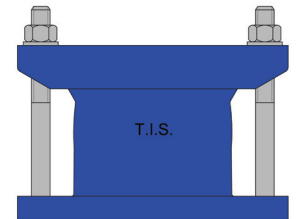
DENOMINAZIONE
PARTMATERIALI
MATERIALS

1	CORPO BODY	GHISA SFEROIDALE DUCTILE IRON
2	GUARNIZIONE GASKET	EPDM EPDM
3	VITE, DADO, RONDELLA SCREW, NUT, WASHER	ACCIAIO STEEL

DN	RANGE	D	A	L	H	n-M
50	59-72	165	80	130	155	2-M12
65	72-85	185	80	130	170	2-M12
80	88-103	200	80	130	185	4-M12
100	109-128	220	80	130	215	4-M12
125	138-153	250	80	130	240	4-M12
150	159-182	285	80	140	275	4-M12
200	218-235	340	80	140	320	4-M12
250	272-289	400	90	150	380	6-M12
300	315-332	455	90	150	423	6-M12

RIVESTIMENTO ESTERNO/INTERNO: Polvere epossidica di colore BLU RAL 5005 con spessore min 250 μ m.

SURFACE PROTECTION: FBE coating process with epoxy resin powder of sky blue color RAL 5005 and minimum thickness of 250 μ m.