

PN 10 - Art. C070 TIS

PN 16 - Art. C071 TIS

VALVOLA DI RITEGNO A CLAPET PN10/16

SWING CHECK VALVE PN10/16

APPLICAZIONE:

Installazione per acqua fredda, e fluidi non aggressivi.

APPLICATION:

Suitable for cold installation and not acidic fluid water installation.

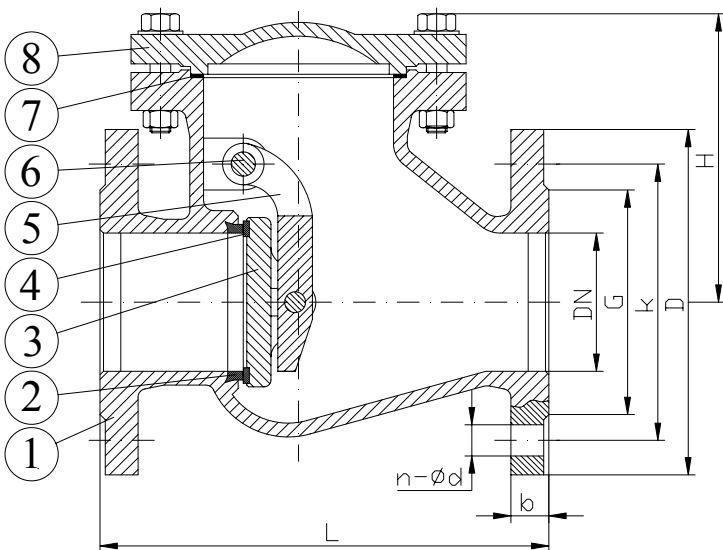
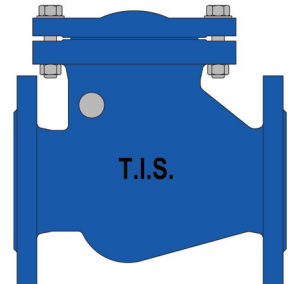

NORMA PROGETTO:	EN 1074-3
SCARTAMENTO:	EN 558-1 Serie48
FLANGE:	EN1092-2
COLLAUDI:	EN 12266
TEMP. ESERCIZIO:	≤80°C
DESIGN STANDARD:	EN 1074-3
FACE TO FACE:	EN 558-1 Serie48
FLANGES:	EN1092-2
TESTS:	EN 12266
WORKING TEMP.:	≤80°C

DENOMINAZIONE PART	MATERIALI MATERIALS
1 CORPO BODY	GJL 250 GJL 250
2 TENUTA CORPO BODY SEAL RING	OTTONE BRASS
3 DISCO DISC	GJL 250 GJL 250
4 TENUTA DISCO DISC SEAL RING	GOMMA EPDM EPDM RUBBER
5 PERNO LEVER PIN	ACCIAIO INOX AISI420 SS AISI420
6 LEVA LEVER	GJS 400 GJS 400
7 GUARNIZIONE GASKET	GRAFITE GRAPHITE
8 CAPPELLO BONNET	GJL 250 GJL 250

COLORE: Blu RAL 5017.

COLOUR: Blue RAL 5017.

DN	G		K		D		L	H	b		n-ød		W (kg)
	PN10	PN16	PN10	PN16	PN10	PN16			PN10	PN16	PN10	PN16	
40	88	88	110	110	150	150	180	120	18	18	4-18	4-18	11.5
50	102	102	125	125	165	165	200	140	20	20	4-18	4-18	13.6
65	122	122	145	145	185	185	240	150	20	20	4-18	4-18	21
80	138	138	160	160	200	200	260	165	22	22	4-18	8-18	26.5
100	158	158	180	180	220	220	300	175	24	24	8-18	8-18	32
125	188	188	210	210	250	250	350	198	26	26	8-18	8-18	45
150	212	212	240	240	285	285	400	229	26	26	8-18	8-18	71.5
200	268	268	295	295	340	340	500	249	26	30	8-23	12-23	95
250	320	320	350	355	395	405	600	310	28	32	12-23	12-27	139
300	370	378	400	410	445	460	700	322	28	32	12-23	12-27	188

PN 10 - Art. C070

PN 16 - Art. C071

VALVOLA DI RITEGNO A CLAPET PN10/16

SWING CHECK VALVE PN10/16

APPLICAZIONE:

Installazione per acqua fredda, e fluidi non aggressivi.

APPLICATION:

Suitable for cold installation and not acidic fluid water installation.

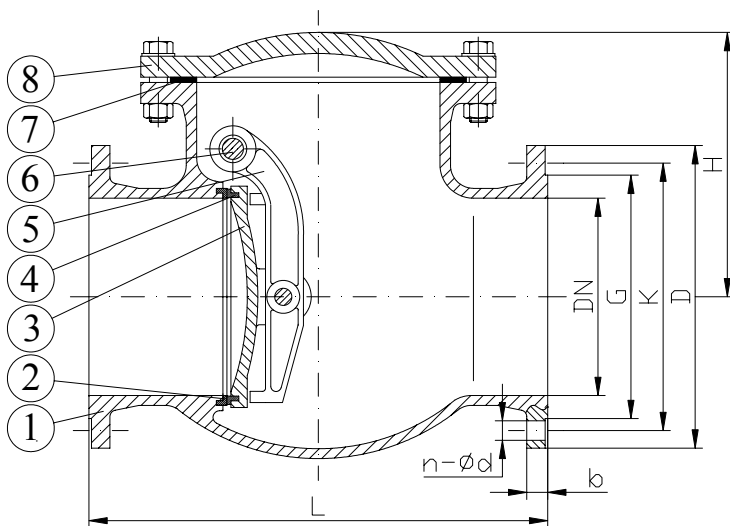

NORMA PROGETTO:	EN 1074-3
SCARTAMENTO:	EN 558-1 Serie48
FLANGE:	EN1092-2
COLLAUDI:	EN 12266
TEMP. ESERCIZIO:	≤80°C
DESIGN STANDARD:	EN 1074-3
FACE TO FACE:	EN 558-1 Serie48
FLANGES:	EN1092-2
TESTS:	EN 12266
WORKING TEMP.:	≤80°C

DENOMINAZIONE PART	MATERIALI MATERIALS
1 CORPO BODY	GJS 500 GJS 500
2 TENUTA CORPO BODY SEAL RING	OTTONE BRASS
3 DISCO DISC	GJS 500 GJS 500
4 TENUTA DISCO DISC SEAL RING	OTTONE BRASS
5 PERNO LEVER PIN	ACCIAIO INOX AISI420 SS AISI420
6 LEVA LEVER	GJS 500 GJS 500
7 GUARNIZIONE GASKET	GOMMA EPDM EPDM RUBBER
8 CAPPELLO BONNET	GJS 500 GJS 500

COLORE: Blu RAL 5015.

COLOUR: Blue RAL 5015.

DN	G		K		D		L	H	b		n-ød		W (kg)	
	PN10	PN16	PN10	PN16	PN10	PN16			PN10	PN16	PN10	PN16	PN10	PN16
350	429	429	460	470	505	520	800	430	24.5	26.5	16-23	16-28	434	482
400	480	480	515	525	565	580	900	480	24.5	28	16-28	16-31	495	550
450	530	548	565	585	640	640	1000	512	30	30	20-28	20-31	668	742
500	582	609	620	650	670	715	1100	525	26.5	31.5	20-28	20-34	718	798
600	682	720	725	770	780	840	1300	608	30	36	20-31	20-37	1200	1330