

Art. 095140

RASCHIATORE TANGENZIALE**SEMIAUTOMATIC SCREAPER****APPLICAZIONE:**

Per tubi in polietilene.

APPLICATION:

For polyethylene pipes.

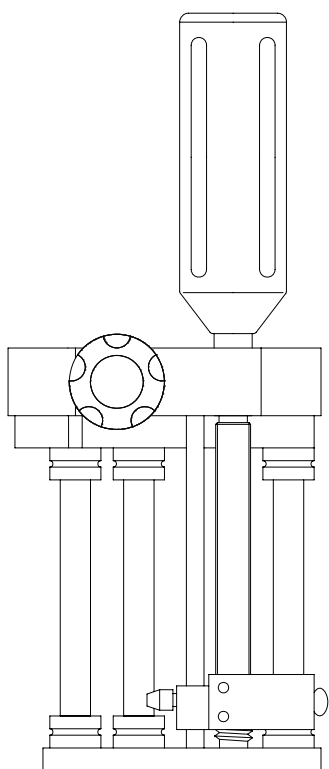
**CODICE
CODE**

095140160

**TIPO
TYPE**SEMIAUTOMATICO
SEMIAUTOMATIC**CAMPO D'IMPIEGO
WORKING RANGE**

25 ÷ 160 mm

**DIMENSIONI
DIMENSIONS**

280 x 110 x 180 mm

**PESO
WEIGHT**

4 Kg

**CODICE
CODE**

095140180

**TIPO
TYPE**SEMIAUTOMATICO
SEMIAUTOMATIC**CAMPO D'IMPIEGO
WORKING RANGE**

75 ÷ 180 mm

**DIMENSIONI
DIMENSIONS**

390 x 170 x 100 mm

**PESO
WEIGHT**

1,9 Kg

**CODICE
CODE**

095140400

**TIPO
TYPE**SEMIAUTOMATICO
SEMIAUTOMATIC**CAMPO D'IMPIEGO
WORKING RANGE**

200 ÷ 400 mm

**DIMENSIONI
DIMENSIONS**

420 x 280 x 110 mm

**PESO
WEIGHT**

6,5 Kg

**CODICE
CODE**

095140630

**TIPO
TYPE**SEMIAUTOMATICO
SEMIAUTOMATIC**CAMPO D'IMPIEGO
WORKING RANGE**

160 ÷ 630 mm

**DIMENSIONI
DIMENSIONS**

455 x 320 x 170 mm

**PESO
WEIGHT**

9 Kg