

FLANGIA A COLLARINO A SALDARE, PN10

WELDING NECK FLANGE, PN10

NORME PRODOTTO:
MATERIALI:

EN 1092-1-11
Acciaio al carbonio

PRODUCT STANDARDS:
MATERIALS:

EN 1092-1-11
Carbon steel

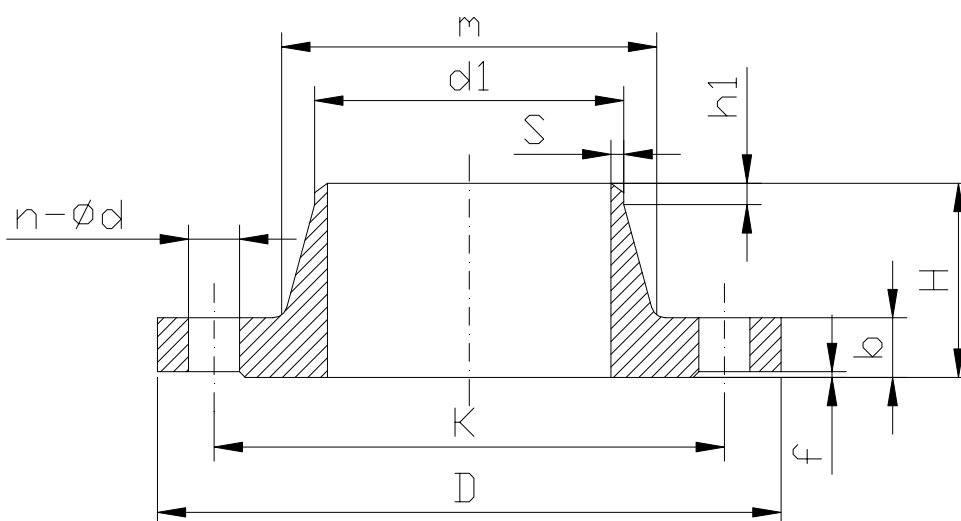

DN	øTUBO-PIPE ISO	d1 ISO	K	D	n-ød	b	VITE SCREW	m ISO	G	H	h1	f	r	s	PESO kg WEIGHT
15	21.3	22.5	65	95	4 - 14	16	M12	32	45	38	6	2	4	2.0	1.0
20	26.9	28	75	105	4 - 14	18	M12	40	58	40	6	2	4	2.3	1.0
25	33.7	34.5	85	115	4 - 14	18	M12	46	68	40	6	2	4	2.6	1.0
32	42.4	43.5	100	140	4 - 18	18	M16	56	78	42	6	2	6	2.6	2.0
40	48.3	49.5	110	150	4 - 18	18	M16	64	88	45	7	3	6	2.6	2.0
50	60.3	61.5	125	165	4 - 18	18	M16	74	102	45	18	3	5	2.9	3.0
65	76.1	77	145	185	8 - 18	18	M16	92	122	45	10	3	6	2.9	3.0
80	88.9	90	160	200	8 - 18	20	M16	105	138	50	10	3	6	3.2	4.0
100	114.3	115.5	180	220	8 - 18	20	M16	131	158	52	12	3	8	3.6	4.5
125	139.7	141	210	250	8 - 18	22	M16	156	188	55	12	3	8	4.0	6.5
150	168.3	170.5	240	285	8 - 22	22	M20	184	212	55	12	3	10	4.5	7.5
200	219.1	221	295	340	8 - 22	24	M20	234	268	62	16	3	10	6.3	11.5
250	273	275	350	395	12 - 22	26	M20	292	320	68	16	3	12	6.3	15.5
300	323.9	326	400	445	12 - 22	26	M20	342	370	68	16	4	12	7.1	18.0
350	355.6	357.5	460	505	16 - 22	26	M20	385	430	68	16	4	12	7.1	24.5
400	406.4	408.5	515	565	16 - 26	26	M24	440	482	72	16	4	12	7.1	29.5
450	457.2	459	565	615	20 - 26	28	M24	488	532	72	16	4	12	7.1	34.0
500	508	510	620	670	20 - 26	28	M24	542	585	75	16	4	12	7.1	39.5
600	609.6	611.5	725	780	20 - 30	30	M27	642	685	82	18	5	12	7.1	60.0
700	711.3	715	840	895	24 - 30	35	M27	746	800	85	18	5	12	8.0	76.0
800	812.8	817	950	1015	24 - 33	38	M30	850	905	96	18	5	12	8.0	103.0
900	914.4	918	1050	1115	28 - 33	38	M30	950	1005	99	20	5	12	10.0	118.0
1000	1016	1020	1160	1230	28 - 36	44	M33	1052	1110	105	20	5	16	10.0	159.0

FLANGIA A COLLARINO A SALDARE, PN16

WELDING NECK FLANGE, PN16

NORME PRODOTTO:
MATERIALI:

EN 1092-1-11
Acciaio al carbonio

PRODUCT STANDARDS:
MATERIALS:

EN 1092-1-11
Carbon steel

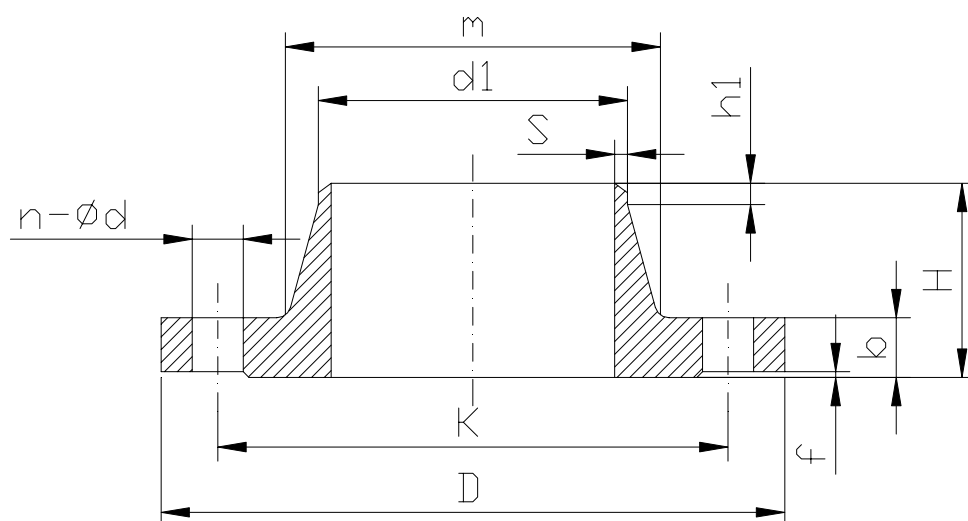

DN	øTUBO-PIPE ISO	d1 ISO	K	D	n-ød	b	VITE SCREW	m ISO	G	H	h1	f	r	s	PESO kg WEIGHT
15	21.3	22.5	65	95	4 - 14	16	M12	32	45	38	6	2	4	2.0	1.0
20	26.9	28	75	105	4 - 14	18	M12	40	58	40	6	2	4	2.3	1.0
25	33.7	34.5	85	115	4 - 14	18	M12	45	68	40	6	2	4	2.6	1.0
32	42.4	43.5	100	140	4 - 18	18	M16	56	78	42	6	2	6	2.6	2.0
40	48.3	49.5	110	150	4 - 18	18	M16	64	88	45	7	3	6	2.6	2.0
50	60.3	61.5	125	165	4 - 18	18	M16	75	102	45	8	3	6	2.9	3.0
65	76.1	77	145	185	8 - 18	18	M16	92	122	45	10	3	6	2.9	3.0
80	88.9	90	160	200	8 - 18	20	M16	105	138	50	10	3	8	3.2	4.0
100	114.3	115.5	180	220	8 - 18	20	M16	131	158	52	12	3	8	3.6	4.5
125	139.7	141	210	250	8 - 18	22	M16	156	188	55	12	3	8	4.0	6.5
150	168.3	170.5	240	285	8 - 22	22	M20	184	212	55	12	3	10	4.5	7.5
200	219.1	221	295	340	12 - 22	24	M20	235	268	62	16	3	10	6.3	11.0
250	273	275	355	405	12 - 26	26	M24	292	320	70	16	3	12	6.3	16.5
300	323.9	326	410	460	12 - 26	28	M24	344	378	78	16	4	12	7.1	22.0
350	355.6	357.5	470	520	16 - 26	30	M24	390	438	82	16	4	12	8.0	32.0
400	406.4	408.5	525	580	16 - 30	32	M27	445	490	85	16	4	12	8.0	40.0
450	457.2	459	585	640	20 - 30	34	M27	490	550	87	16	4	12	8.0	49.5
500	508	510	650	715	20 - 33	36	M30	548	610	90	16	4	12	8.0	60.0
600	609.6	611.5	770	840	20 - 36	40	M33	652	725	95	18	5	12	8.8	85
700	711.3	715	840	910	24 - 36	40	M33	755	795	100	18	5	12	8.8	96.0
800	812.8	817	950	1025	24 - 39	41	M36	855	900	105	20	5	12	10.0	119.0
900	914.4	918	1050	1125	28 - 39	48	M36	955	1000	110	20	5	12	10.0	159.0
1000	1016	1020	1170	1255	28 - 42	59	M39	1058	1115	120	22	5	16	10.0	237.0

FLANGIA A COLLARINO A SALDARE, PN25

WELDING NECK FLANGE, PN25

NORME PRODOTTO: EN 1092-1-11
MATERIALI: Acciaio al carbonio

PRODUCT STANDARDS: EN 1092-1-11
MATERIALS: Carbon steel

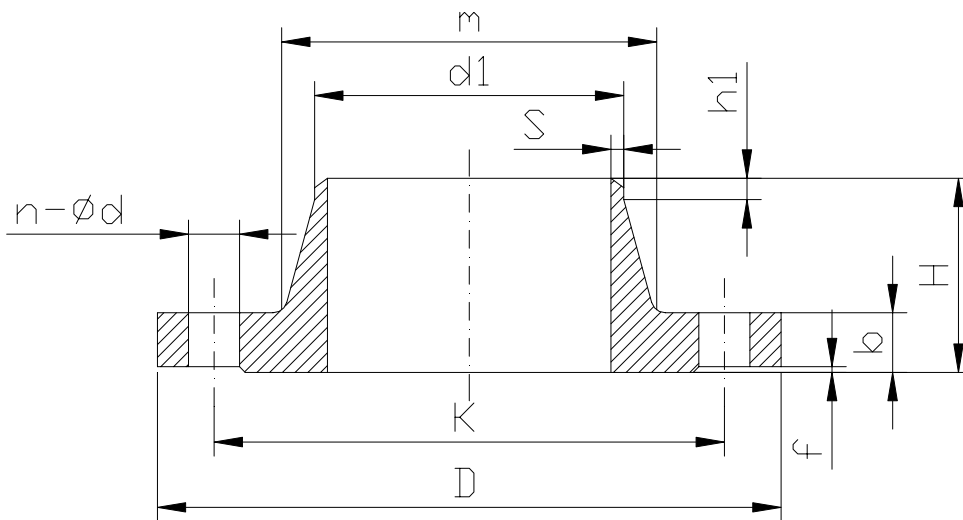

DN	øTUBO-PIPE ISO	d1 ISO	K	D	n-ød	b	VITE SCREW	m ISO	G	H	h1	f	r	s	PESO kg WEIGHT
15	21.3	22.5	65	95	4 - 14	16	M12	32	45	38	6	2	4	2.0	1.0
20	26.9	28	75	105	4 - 14	18	M12	40	58	40	6	2	4	2.3	1.0
25	33.7	34.5	85	115	4 - 14	18	M12	46	68	40	6	2	4	2.6	1.0
32	42.4	43.5	100	140	4 - 18	18	M16	56	78	42	6	2	6	2.6	2.0
40	48.3	49.5	110	150	4 - 18	18	M16	64	88	45	7	3	6	2.6	2.0
50	60.3	61.5	125	165	4 - 18	20	M16	75	102	48	8	3	6	2.9	3.0
65	76.1	77	145	185	8 - 18	22	M16	90	122	52	10	3	6	2.9	4.0
80	88.9	90	160	200	8 - 18	24	M16	105	138	58	12	3	8	3.2	5.0
100	114.3	115.5	190	235	8 - 22	24	M20	134	162	65	12	3	8	3.6	6.5
125	139.7	141	220	270	8 - 26	26	M24	162	188	68	12	3	8	4.0	9.0
150	168.3	170.5	250	300	8 - 26	28	M24	192	218	75	12	3	10	4.5	11.5
200	219.1	221	310	360	12 - 26	30	M24	244	278	80	16	3	10	6.3	17.0
250	273	275	370	425	12 - 30	32	M27	298	335	88	18	3	12	7.1	23.0
300	323.9	326	430	485	16 - 30	34	M27	352	395	92	18	4	12	8.0	28.5
350	355.6	357.5	490	555	16 - 33	38	M30	398	450	100	20	4	12	8.0	43.0
400	406.4	408.5	550	620	16 - 36	40	M33	452	505	110	20	4	12	8.8	55.0
450	457.2	459	600	670	20 - 36	46	M33	500	555	110	20	4	12	8.8	69.5
500	508	510	660	730	20 - 36	48	M33	558	615	125	20	4	12	10.0	82.5
600	609.6	611.5	770	845	20 - 39	48	M36	660	720	125	20	5	12	11.0	97
700	711.3	715	875	960	24 - 42	50	M39	760	820	125	20	5	12	12.5	143.5
800	812.8	817	990	1085	24 - 48	53	M45	865	930	135	22	5	12	14.0	193.5
900	914.4	918	1090	1185	28 - 48	57	M45	968	1030	145	24	5	12	16.0	237.0
1000	1016	1020	1210	1320	28 - 56	63	M52	1070	1140	155	24	5	16	17.5	310.5

FLANGIA A COLLARINO A SALDARE, PN40

WELDING NECK FLANGE, PN40

NORME PRODOTTO:
MATERIALI:

EN 1092-1-11
Acciaio al carbonio

PRODUCT STANDARDS:
MATERIALS:

EN 1092-1-11
Carbon steel

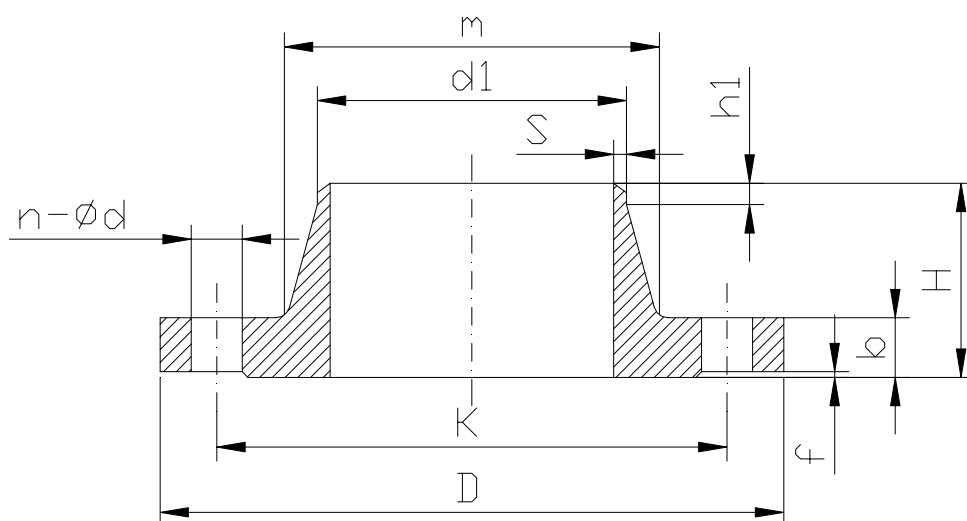

DN	øTUBO-PIPE ISO	d1 ISO	K	D	n-ød	b	VITE SCREW	m ISO	G	H	h1	f	r	s	PESO kg WEIGHT
15	21.3	22.5	65	95	4 - 14	16	M12	32	45	38	6	2	4	2.0	1.0
20	26.9	28	75	105	4 - 14	18	M12	40	58	40	6	2	4	2.3	1.0
25	33.7	34.5	85	115	4 - 14	18	M12	46	68	40	6	2	4	2.6	1.0
32	42.4	43.5	100	140	4 - 18	18	M16	56	78	42	6	2	6	2.6	2.0
40	48.3	49.5	110	150	4 - 18	18	M16	64	88	45	7	3	6	2.6	2.0
50	60.3	61.5	125	165	4 - 18	20	M16	75	102	48	8	3	6	2.9	3.0
65	76.1	77	145	185	8 - 18	22	M16	90	122	52	10	3	6	2.9	4.0
80	88.9	90	160	200	8 - 18	24	M16	105	138	58	12	3	8	3.2	5.0
100	114.3	115.5	190	235	8 - 22	24	M20	134	162	65	12	3	8	3.6	6.5
125	139.7	141	220	270	8 - 26	26	M24	162	188	68	12	3	8	4.0	9.0
150	168.3	170.5	250	300	8 - 26	28	M24	192	218	75	12	3	10	4.5	11.5
200	219.1	221	320	375	12 - 30	34	M27	244	285	88	16	3	10	6.3	21.0
250	273	275	385	450	12 - 33	38	M30	306	345	105	18	3	12	7.1	34.0
300	323.9	326	450	515	16 - 33	42	M30	362	410	115	18	4	12	8.0	47.5
350	355.6	357.5	510	580	16 - 36	46	M33	408	465	125	20	4	12	8.8	69.0
400	406.4	408.5	585	660	16 - 39	50	M36	462	535	135	20	4	12	11.0	98.0
450	457.2	459	610	685	20 - 39	57	M36	500	560	135	20	4	12	12.5	106.0
500	508	510	670	755	20 - 42	57	M39	562	615	140	20	4	12	14.2	130.0
600	609.6	611.5	795	890	20 - 48	72	M45	666	735	150	20	5	12	16.0	211.0