

VALVOLA A SFERA FLANGIATA PN16, PASSAGGIO TOTALE, PER GAS NATURALE

FULL BORE FLANGED BALL VALVE PN16, FOR NATURAL GAS

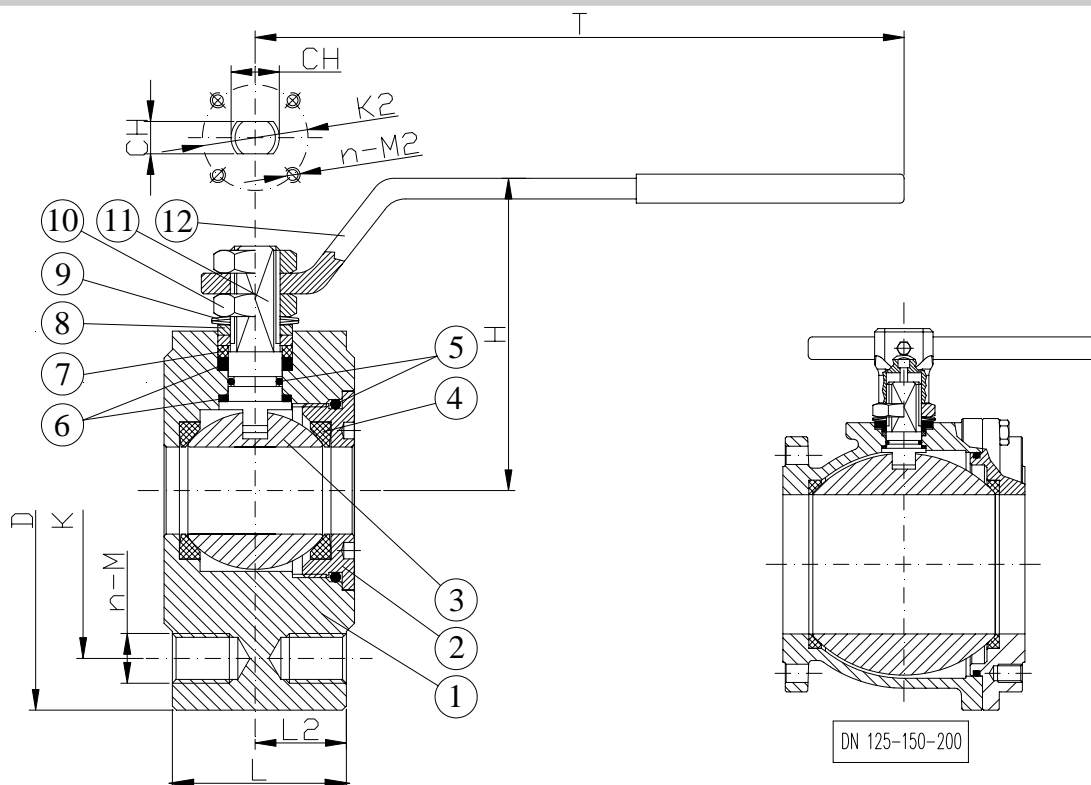

NORMA PROGETTO: UNI 9734
TEMPERATURA ESER: da -20° a $+160^{\circ}\text{C}$
DESIGN STANDARD: UNI 9734
WORKING TEMP: from -20° to $+160^{\circ}\text{C}$

DN	Inch	D	K	n-M	L	L2	H	T	CHx CH	K2	n-M2	W (kg)
15	1/2	90	65	4-M12	35	19	65	132	10x7	32	4-M5	1.3
20	3/4	100	75	4-M12	40	20	69	132	10x7	32	4-M5	1.9
25	1	110	85	4-M12	46	24	80	174	12x8	42	4-M5	2.7
32	1 1/4	130	100	4-M16	54	28	84	174	12x8	42	4-M5	4.2
40	1 1/2	140	110	4-M16	64	32	102	250	16x10	50	4-M6	5.9
50	2	150	125	4-M16	82	41	111	250	16x10	50	4-M6	8.7
65	2 1/2	175	145	4-M16	103	52	128	320	20x14	70	4-M8	15.5
80	3	190	160	8-M16	122	61	138	320	20x14	70	4-M8	20.5
100	4	220	180	8-M16	152	76	156	380	24x18	102	4-M10	34
125	5	250	210	8-M16	196	95	178	380	24x18	102	4-M10	38
150	6	300	240	8-M20	232	116	237	700	42x30	125	4-M12	62
200	8	340	295	12-M20	317	158	280	700	42x30	125	4-M12	99

DENOMINAZIONE PART	MATERIALI MATERIALS
1 CORPO BODY	ACCIAIO ASTM-A105 STEEL ASTM-A105
2 MANICOTTO END CONNECTION	ACCIAIO ASTM-A105 STEEL ASTM-A105
3 SFERA BALL	ACCIAIO INOX A182-F304 STAINLESS STEEL A182-F304
4 GUARNIZIONE SFERA BALL SEAT	PTFE PTFE
5 O-RING O-RING	VITON VITON
6 RONDELLA ASTA STEM GASKET	PTFE PTFE
7 BUSSOLA PACKING GLAND	ACCIAIO AL CARBONIO CARBON STEEL
8 RONDELLA MEZZOGIRO END STOP	ACCIAIO AL CARBONIO CARBON STEEL
9 MOLLA A TAZZA SPRING WASHER	ACCIAIO AL CARBONIO CARBON STEEL
10 DADO NUT	ACCIAIO AL CARBONIO CARBON STEEL
11 ALBERO STEM	ACCIAIO INOX A182-F304 STAINLESS STEEL A182-F304
12 LEVA HANDLE	ACCIAIO AL CARBONIO CARBON STEEL